

CONTENTS

TABLE OF CONTENTS.....1

TABLE OF CONTENTS.....2

AC CIRCUITS/PANELS

AIR CONDITIONING.....3

AIR CONDITIONING OVERVIEW.....4

AC OUTLETS PORT.....5

AC OUTLETS STBD.....6

AC OUTLETS TV.....7

AC PANEL.....8

BATTERY CHARGER.....9

GENERATOR.....10

GYROSCOPIC STABILIZER.....11

REFRIGERATOR, CABIN.....12

REFRIGERATOR, COCKPIT.....13

WATER HEATER.....14

DC CIRCUITS

12V AND USB OUTLETS.....15

AC BOOST, DASH.....16

ACCESSORY RELAY.....17

AUTO FIRE EXTINGUISHER.....18

BATT CHARGING SYSTEM, AUX.....19

BATT CHARGING SYSTEM, START..20

BILGE BLOWERS.....21

BILGE PUMP, CABIN.....22

BILGE PUMPS, EQUIPMENT ROOM..23

BONDING.....24

BOW THRUSTER.....25

CARBON MONOXIDE DETECTOR.....26

DC DISTRIBUTION.....27

DIGITAL BREAKER RESET.....28

DIGITAL SWITCHING CCM 1.....29

DIGITAL SWITCHING CCM 2.....30

DIGITAL SWITCHING CCM 3.....31

DIGITAL SWITCHING OVERVIEW...32

ELECTRICAL FUSE BLOCK.....33

ENGINE FLUSH.....34

EQUIPMENT ROOM HATCH RAM.....35

FUME DETECTOR.....36

GYROSCOPIC STABILIZER.....37

HEAD BLOWER.....38

HIGH WATER ALARM.....39

HORN.....40

CONTENTS

LIGHTS	
CABIN LIGHTS.....	41
COURTESY LIGHTS/REMOTE BOX...	42
DOCKINGS LIGHTS.....	43
EQUIPMENT ROOM.....	44
HEAD LIGHTS.....	45
NAV/ANCH.....	46
SPOTLIGHT.....	47
SPREADER LIGHT.....	48
UNDERWATER.....	49
MACERATOR.....	50
NEMA 2000 OVERVIEW.....	51
SHOWER SUMP.....	52
STEREO AMP.....	53
STEREO AMP 2.....	54
STEREO AMP 3.....	55
STEREO SYSTEM.....	56
SUN ROOF.....	57
SUN SHADE.....	58
TABLE LIFT.....	59
TRIM TABS.....	60
TV INPUT.....	61
VHF RADIO.....	62
VHF RADIO ANTENNA,AUTO.....	63
WASTE SYSTEM.....	64

WASTE SYSTEM (FLOAT).....	65
WASTE SYSTEM (TANK WATCH)....	66
WASTE SYSTEM (TOILET).....	67
WATER PUMP.....	68
WINDLASS.....	69
WIPER.....	70

DC PANELS

ACCESSORY PANEL.....	71
AFT BREAKER PANEL.....	72
CABIN DC PANEL.....	73
DASH BREAKER PANEL.....	74
HELM SWITCH PANEL.....	75

PLUMBING

BILGE PUMPS.....	76
SHOWER SUMP.....	77
WASTE SYSTEM.....	78
WATER SYSTEM.....	79

FUEL SYSTEM

FUEL SYSTEM GAS.....	80
----------------------	----

CABIN AIR CONDITIONER
(LOCATED IN PORT STORAGE
OF THE CABIN)

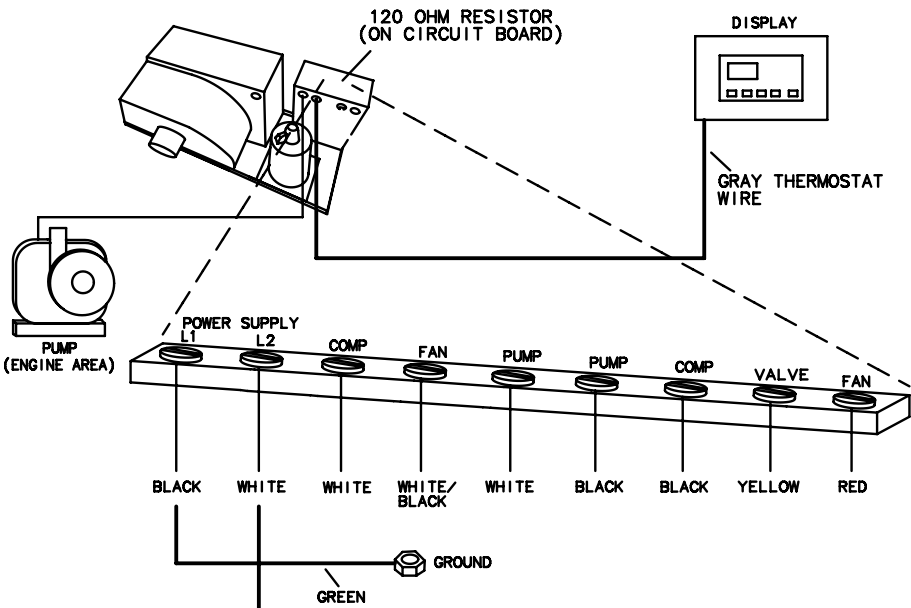

CABIN AIR COND BREAKER
(120V AC SYSTEM PANEL)
(REAR VIEW)

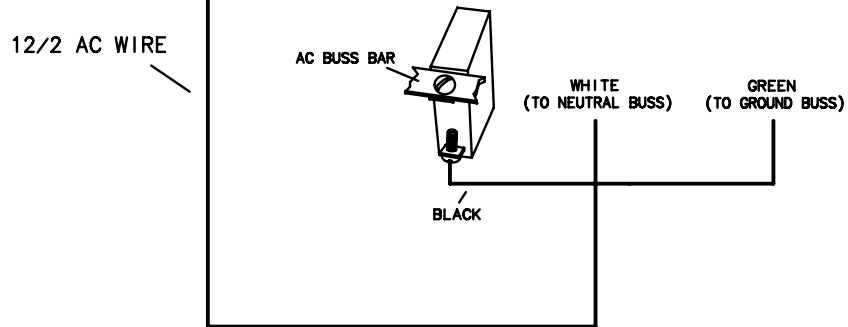

COCKPIT AIR CONDITIONER
(LOCATED IN HELM SEAT)

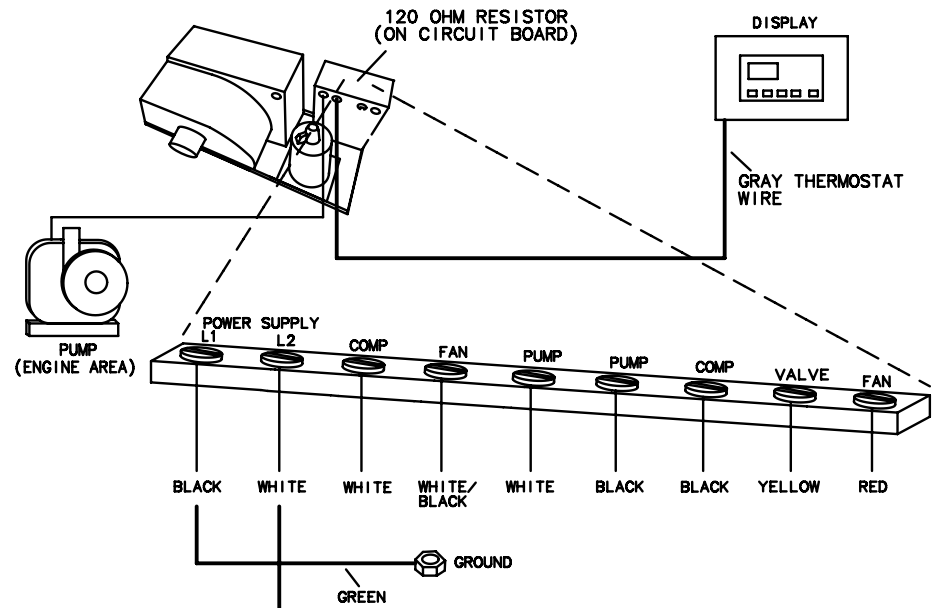

COCKPIT AIR COND BREAKER
(120V AC SYSTEM PANEL)
(REAR VIEW)

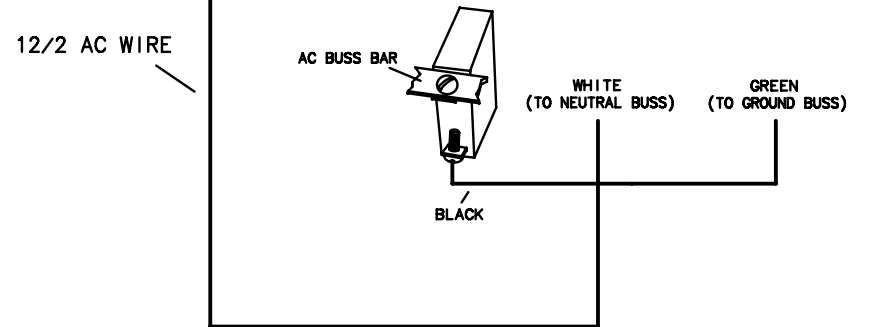

TITLE: AIR CONDITIONERS		THUNDERBIRD PRODUCTS
		P.O. BOX 1003
MOD.: 400 SSC	DR BY: KPP	DECATUR IN., 46733
NO.: 3	DATE:10-5-18	(260) 724-9111

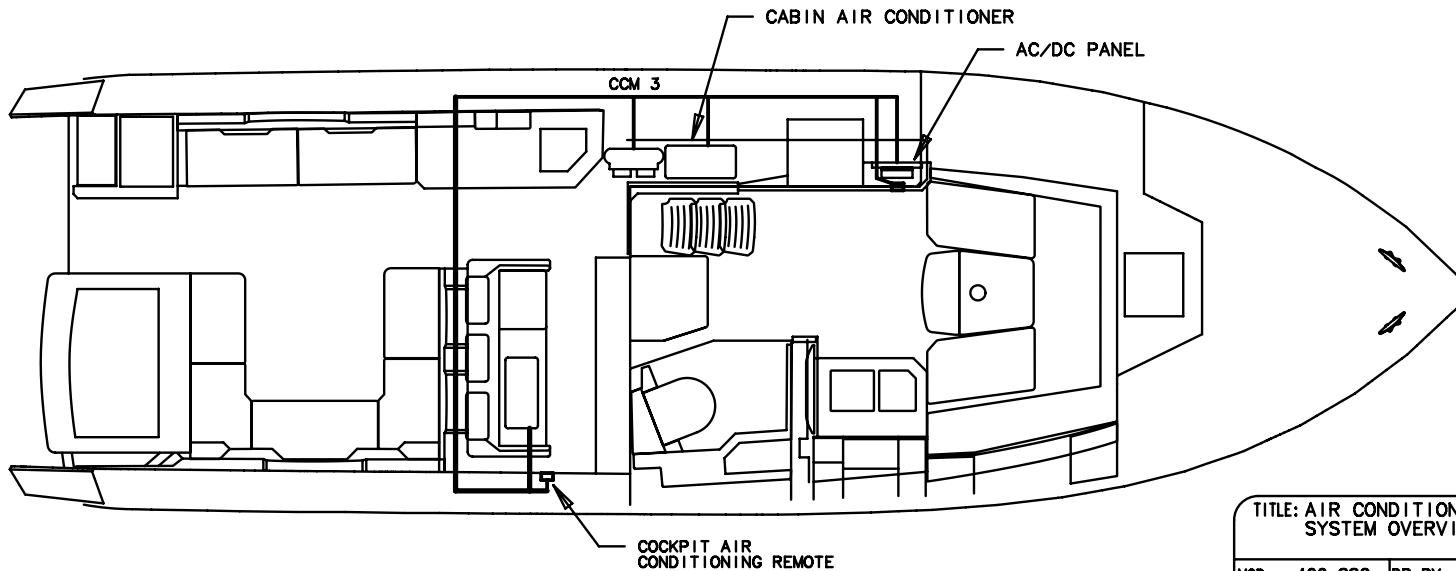
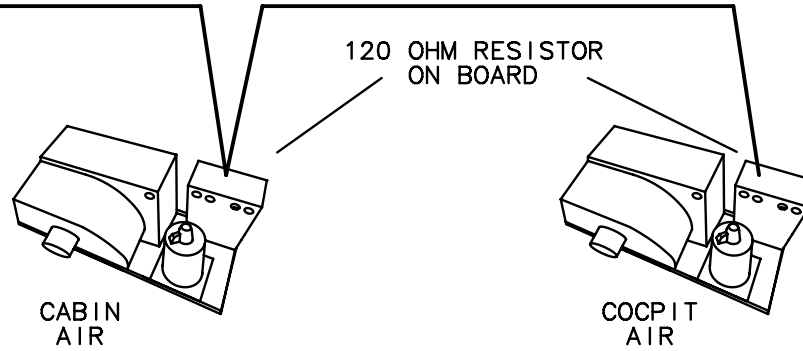
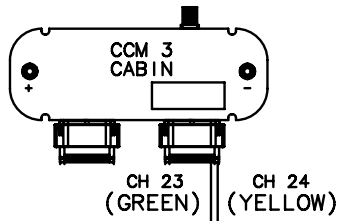

TITLE: AIR CONDITIONING SYSTEM OVERVIEW		THUNDERBIRD PRODUCTS
		P.O. BOX 1003
MOD.: 400 SSC	DR BY: KPP	DECATUR IN., 46733
NO.: 4	DATE:10-5-18	(260) 724-9111

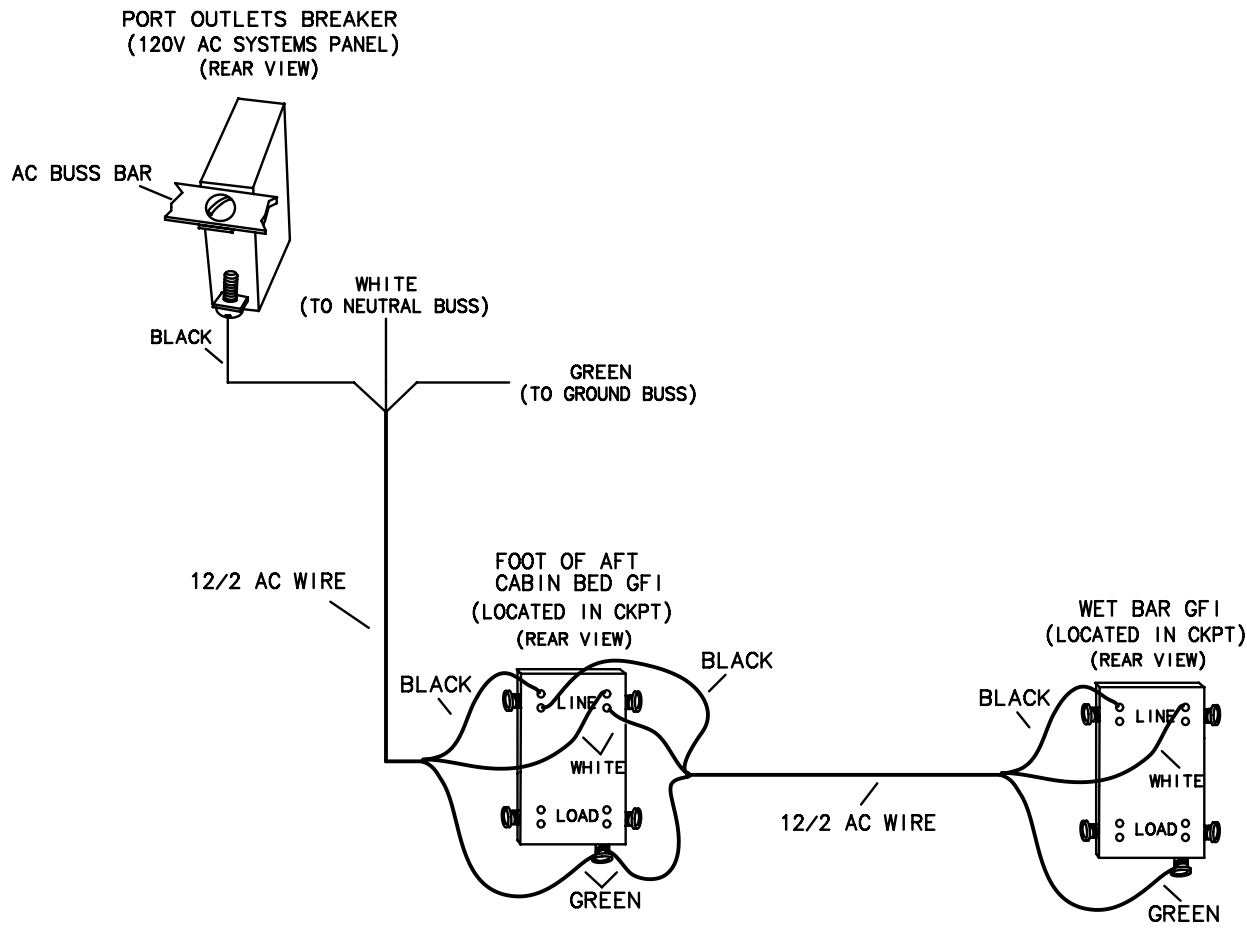

TITLE: AC OUTLETS PORT		THUNDERBIRD PRODUCTS
		P.O. BOX 1003
MOD.: 400 SSC	DR BY: KPP	DECATUR IN., 46733
NO.: 5	DATE:10-5-18	(260) 724-9111

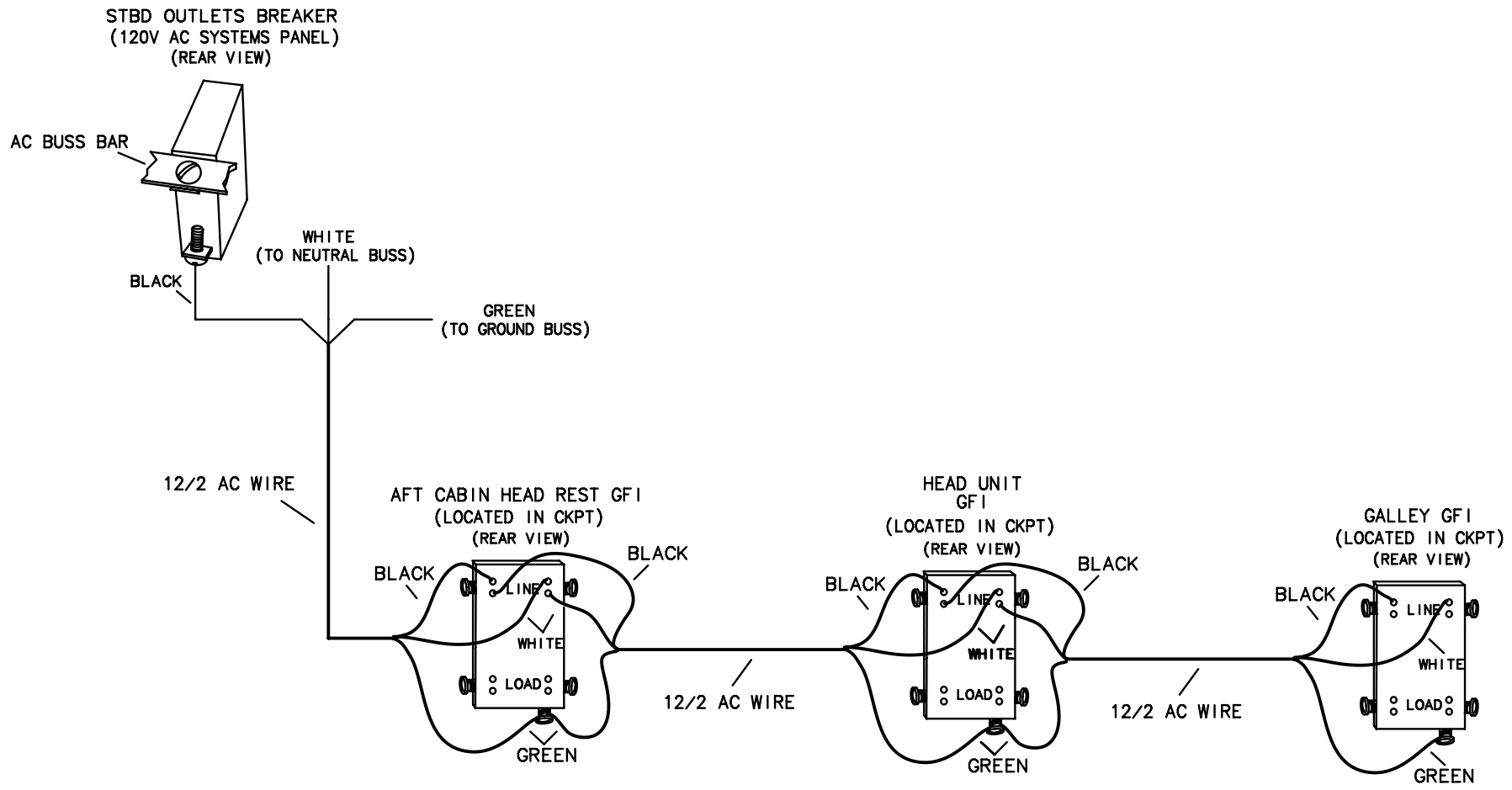

TITLE: AC OUTLETS STBD		THUNDERBIRD PRODUCTS
		P.O. BOX 1003
MOD.: 400 SSC	DR BY: KPP	DECATUR IN., 46733
NO.: 6	DATE:10-5-18	(260) 724-9111

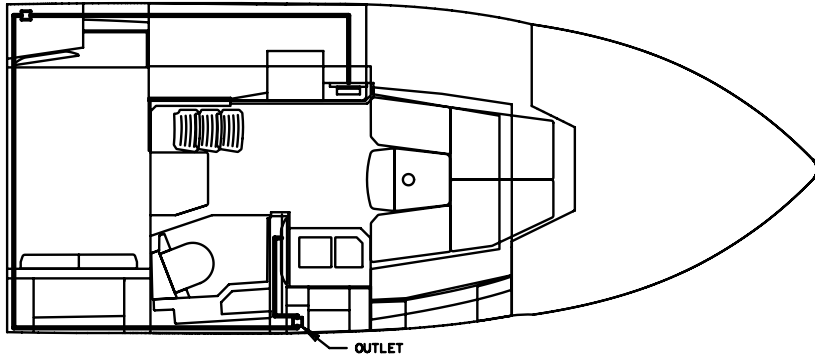
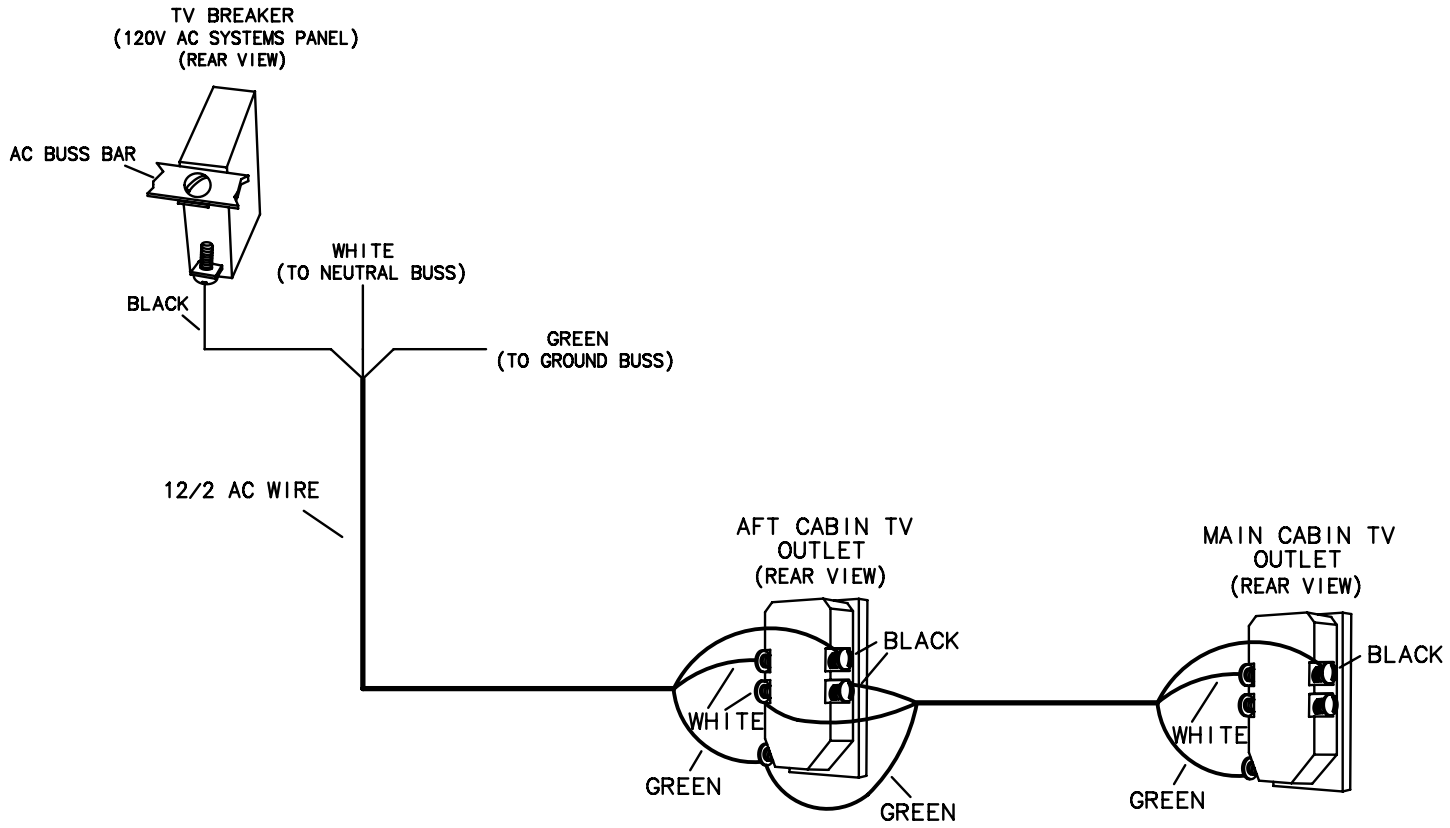

TITLE: AC OUTLETS, TV		THUNDERBIRD PRODUCTS
		P.O. BOX 1003
MOD.: 400 SSC	DR BY: KPP	DECATUR IN., 46733
NO.: 7	DATE: 10-5-18	(260) 724-9111

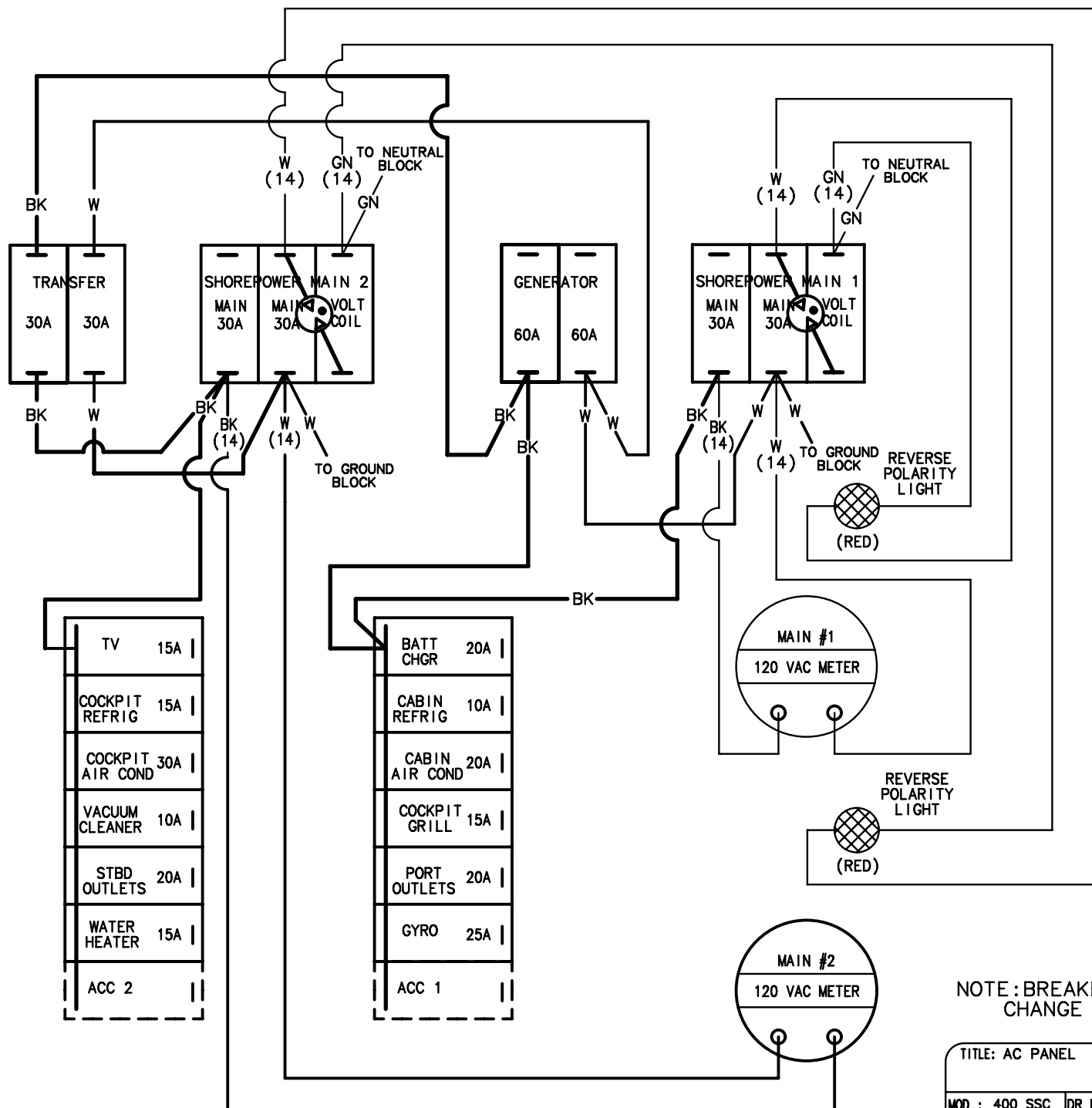

NOTE: BREAKER SIZES SUBJECT TO CHANGE WITHOUT NOTICE.

TITLE: AC PANEL		THUNDERBIRD PRODUCTS
		P.O. BOX 1003
MOD.: 400 SSC	DR BY: KPP	DECATUR IN., 46733
NO.: 8	DATE: 10-5-18	(260) 724-9111

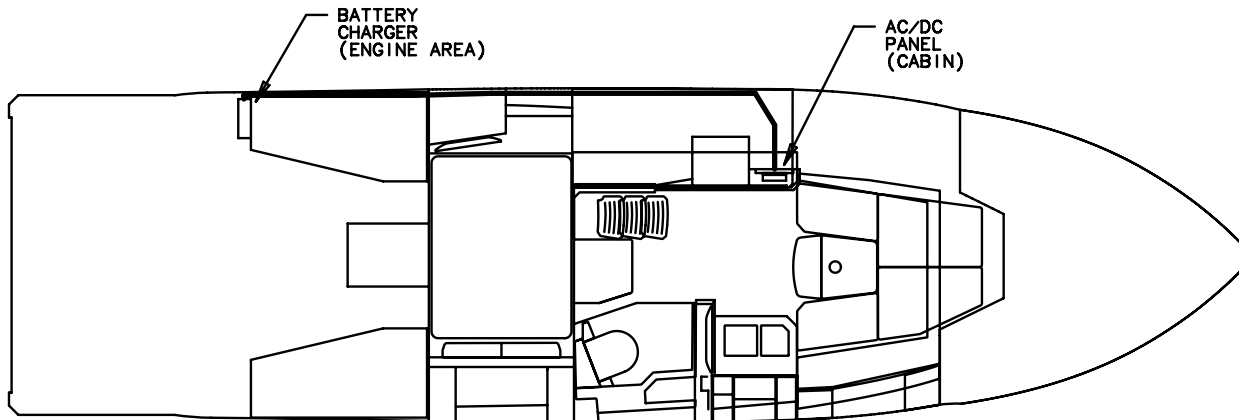
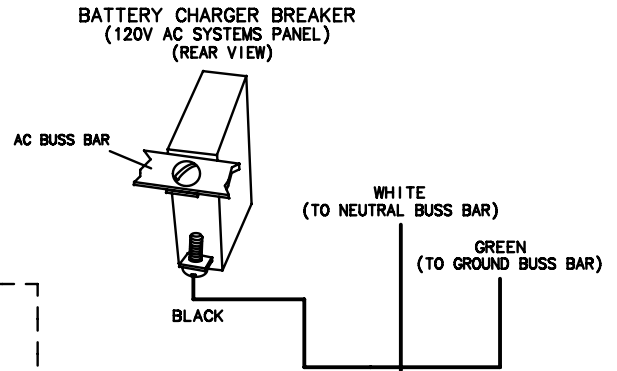
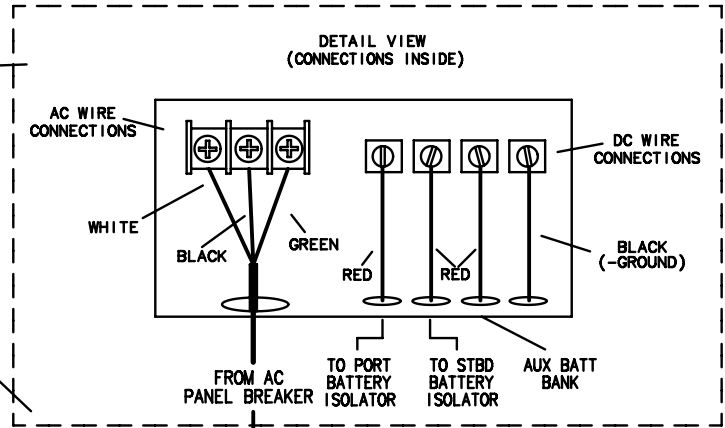
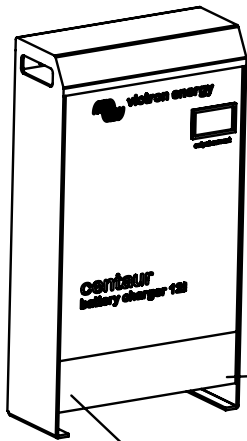

TITLE: BATTERY CHARGER		THUNDERBIRD PRODUCTS
		P.O. BOX 1003
MOD.: 400 SSC	DR BY: KPP	DECATUR IN., 46733
NO.: 9	DATE: 10-4-18	(260) 724-9111

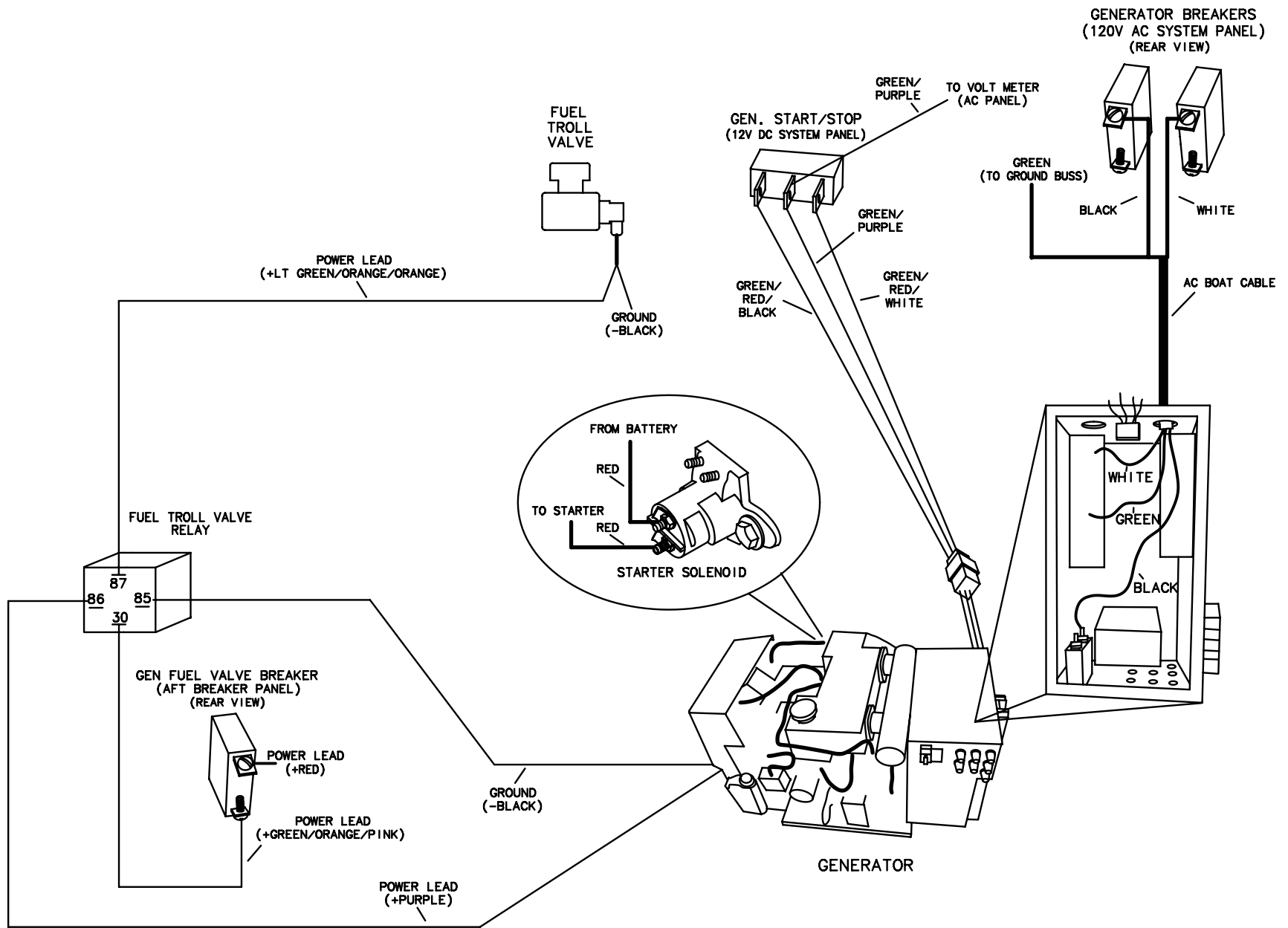

TITLE: GENERATOR (WESTERBEKE)		THUNDERBIRD PRODUCTS
		P.O. BOX 1003
MOD.: 400 SSC	DR BY: KPP	DECATUR IN., 46733
NO.: 10	DATE: 10-5-18	(260) 724-9111

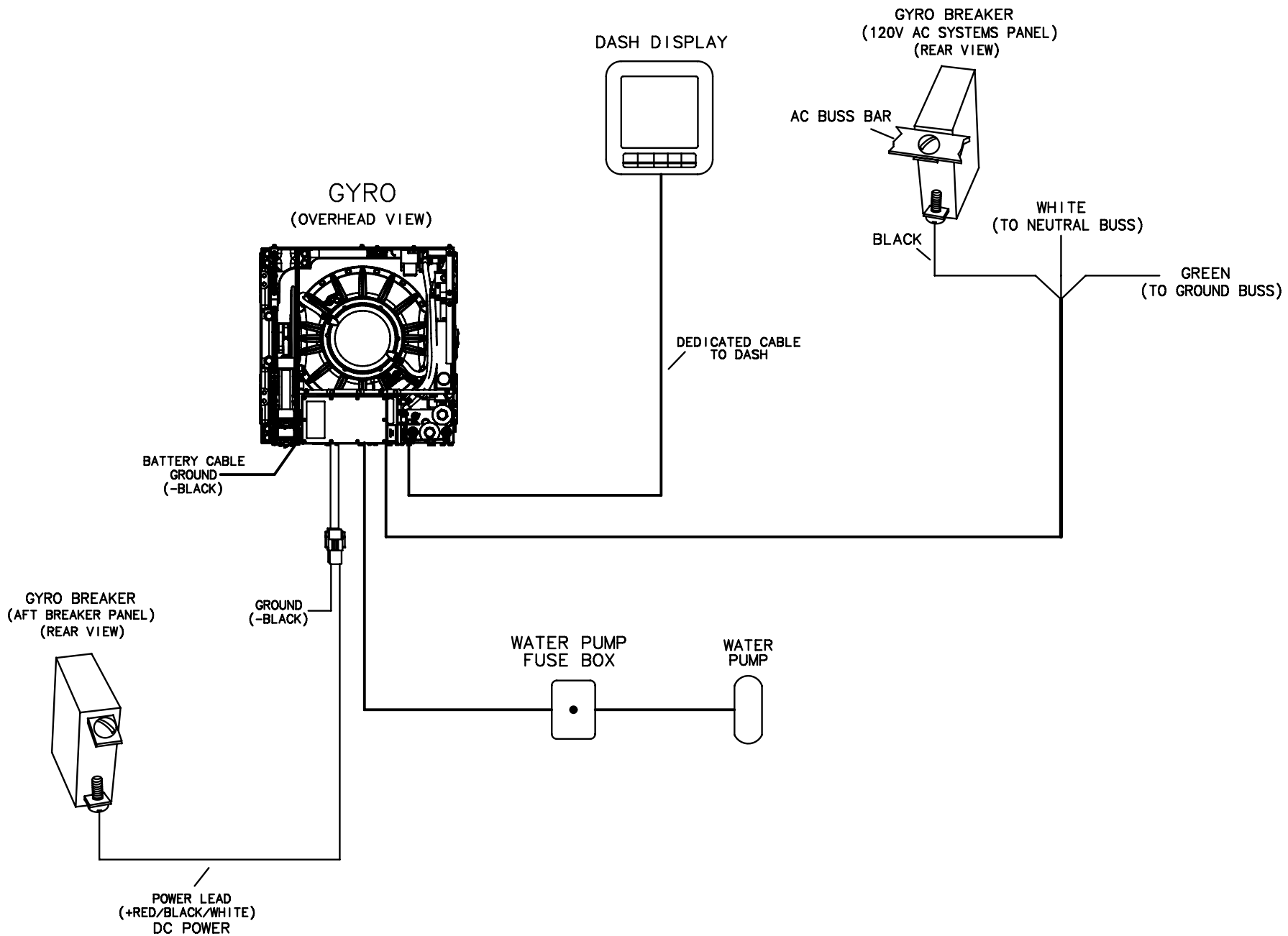

TITLE: GYROSCOPIC STABILIZER SEAKEEPER 6		THUNDERBIRD PRODUCTS
		P.O. BOX 1003
MOD.: 400 SSC	DR BY: KPP	DECATUR IN., 46733
NO.: 11	DATE: 10-5-18	(260) 724-9111

LEGEND

PLUG INTERCONNECT 

DC WIRES 

AC WIRES 

CABIN REFRIG BREAKER
(CABIN DC BREAKER PANEL)
(REAR VIEW)

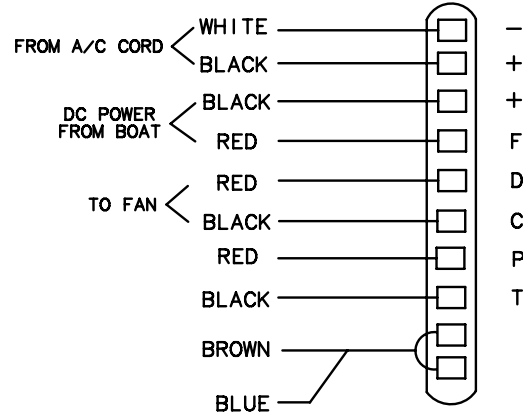
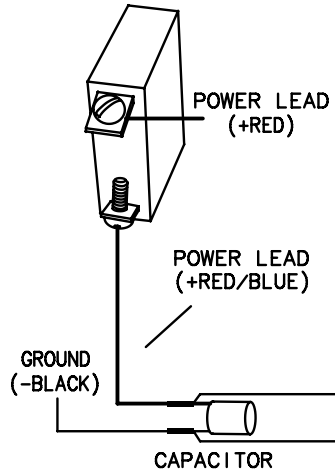

CABIN REFRIG BREAKER
(120V AC SYSTEMS PANEL)
(REAR VIEW)

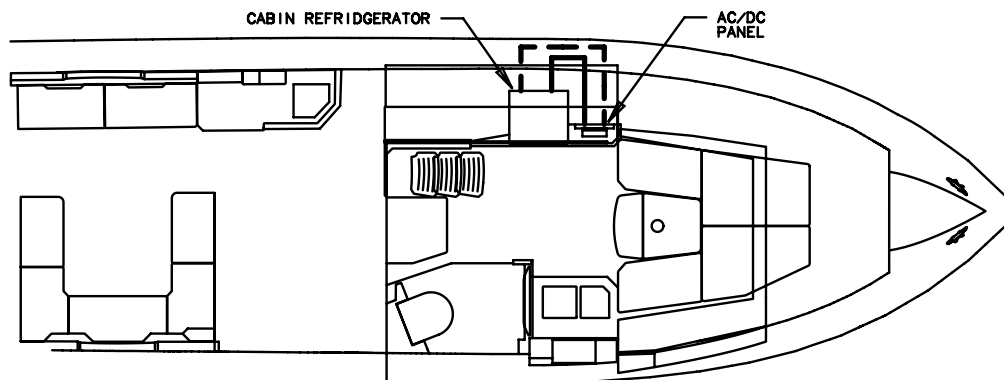
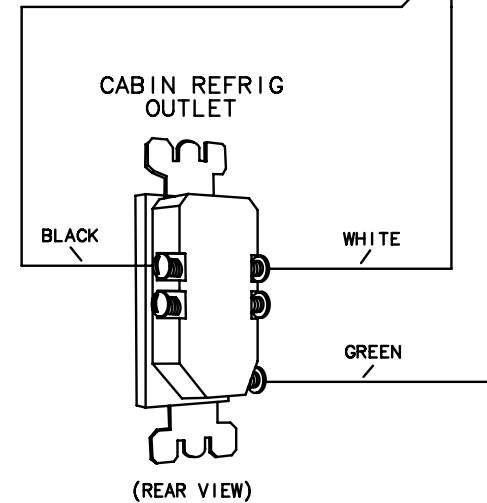
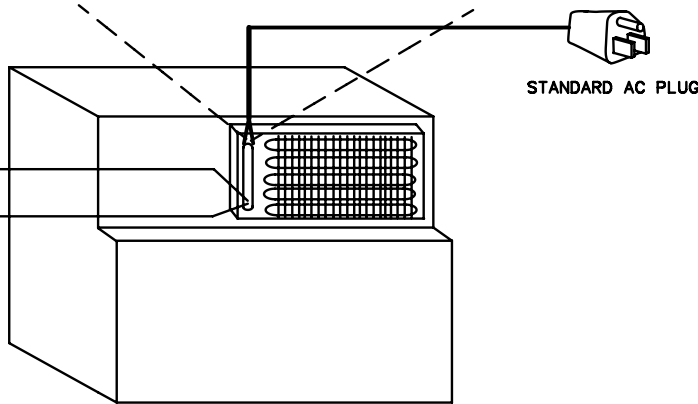
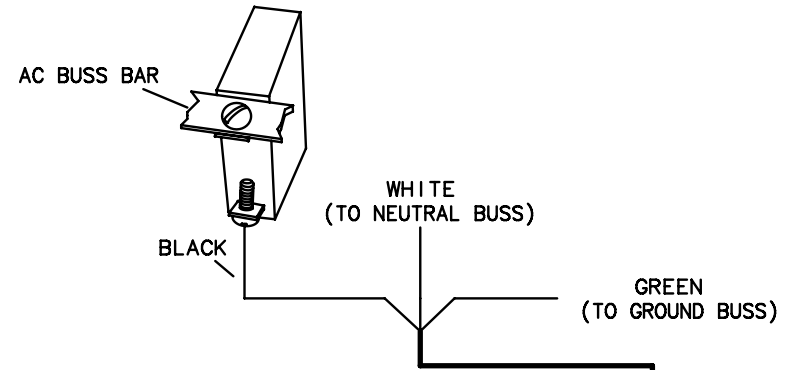

TITLE: CABIN REFRIDGERATOR		THUNDERBIRD PRODUCTS
		P.O. BOX 1003
MOD.: 400 SSC	DR BY: KPP	DECATUR IN., 46733
NO.: 12	DATE:10-5-18	(260) 724-9111

LEGEND

PLUG INTERCONNECT 

DC WIRES 

AC WIRES 

COCKPIT REFRIG BREAKER
(CABIN DC BREAKER PANEL)
(REAR VIEW)

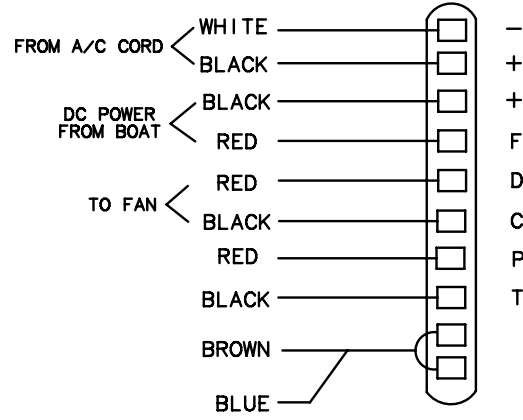
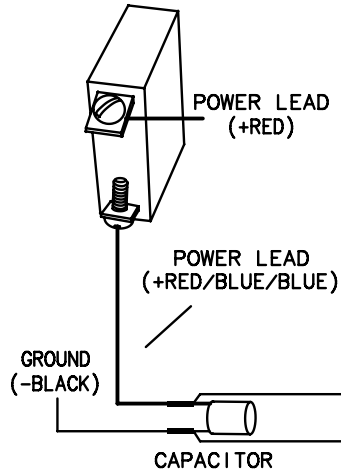

COCKPIT REFRIG BREAKER
(120V AC SYSTEMS PANEL)
(REAR VIEW)

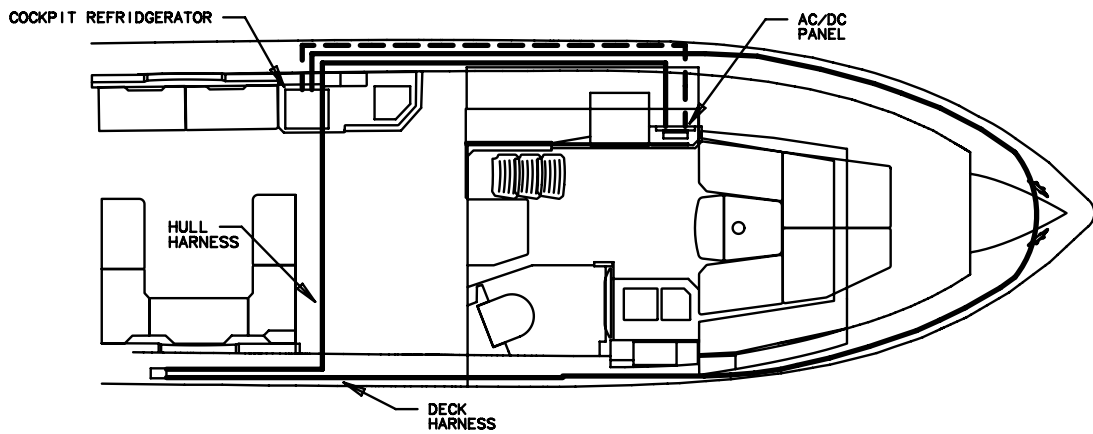
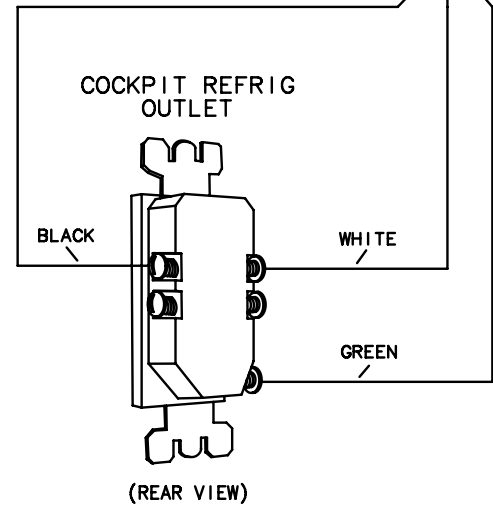
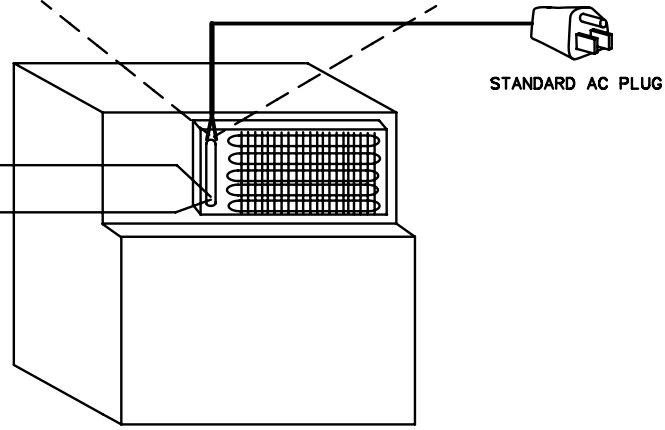
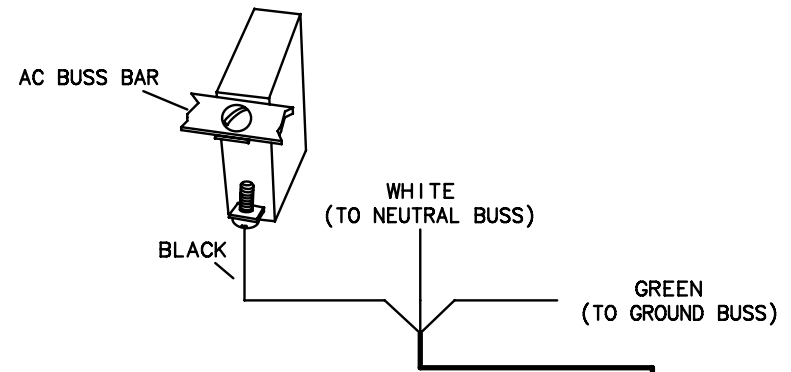

TITLE: COCKPIT REFRIDGERATOR		THUNDERBIRD PRODUCTS
		P.O. BOX 1003
MOD.: 400 SSC	DR BY: KPP	DECATUR IN., 46733
NO.: 13	DATE:10-5-18	(260) 724-9111

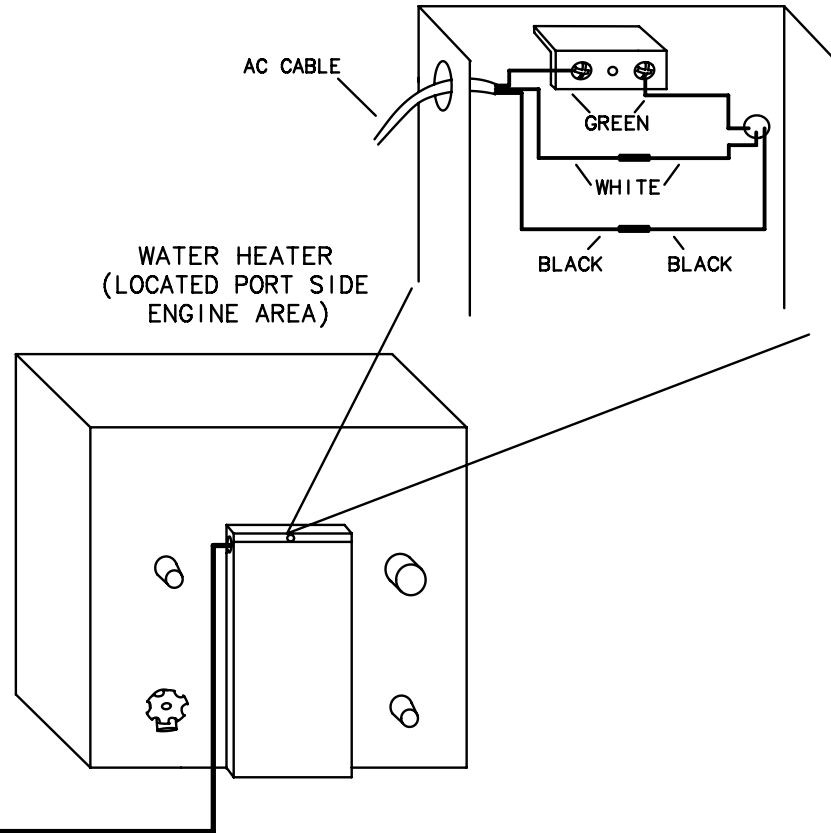
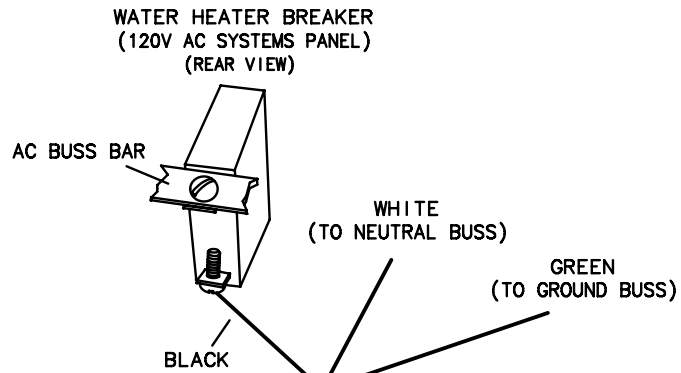

TITLE: WATER HEATER		THUNDERBIRD PRODUCTS
		P.O. BOX 1003
MOD.: 400 SSC	DR BY: KPP	DECATUR IN., 46733
NO.: 14	DATE:10-5-18	(260) 724-9111

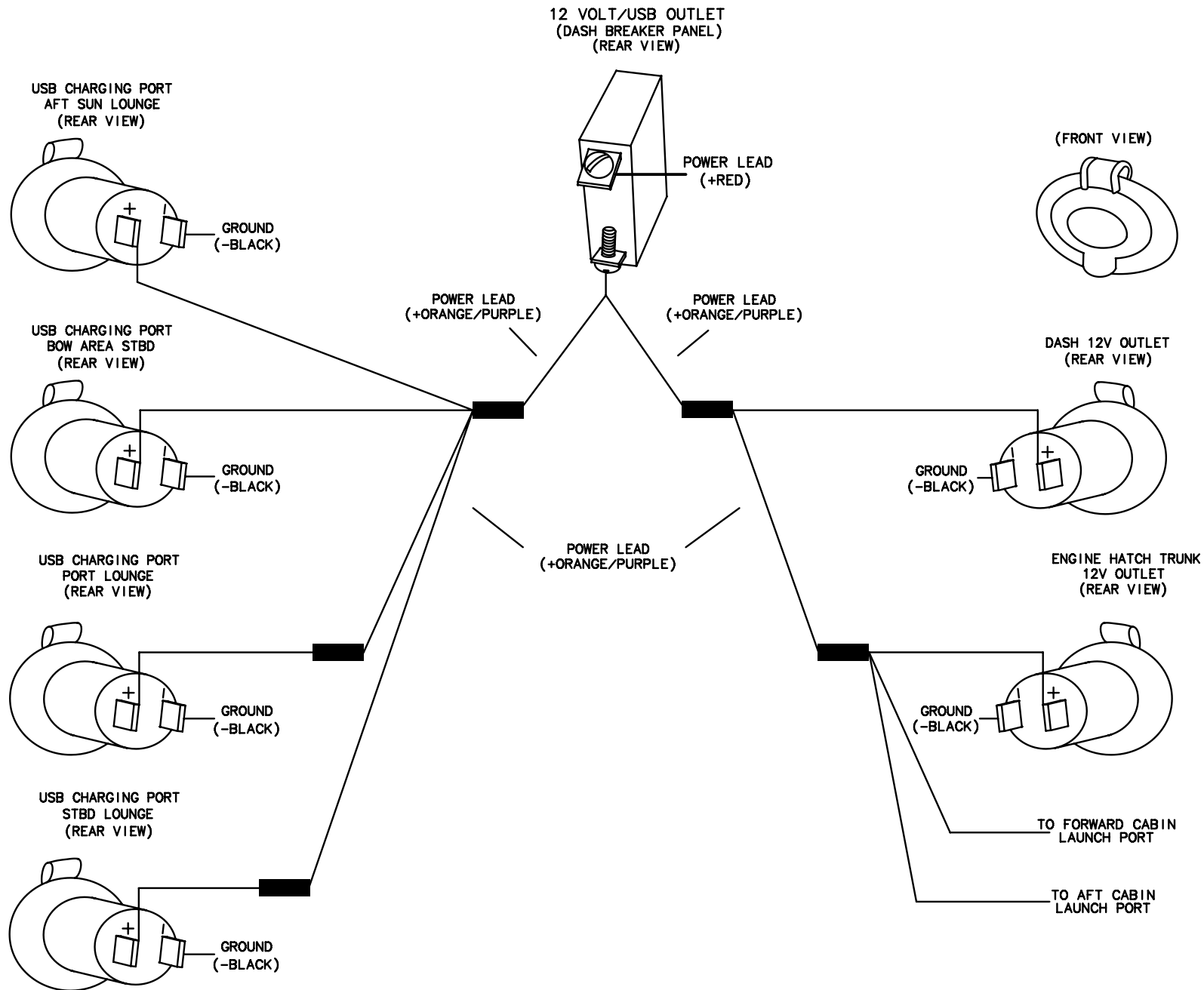

TITLE: 12V/USB OUTLETS/ LAUNCH PORTS		THUNDERBIRD PRODUCTS
		P.O. BOX 1003
MOD.: 400 SSC	DR BY: KPP	DECATUR IN., 46733
NO.: 15	DATE:10-5-18	(260) 724-9111

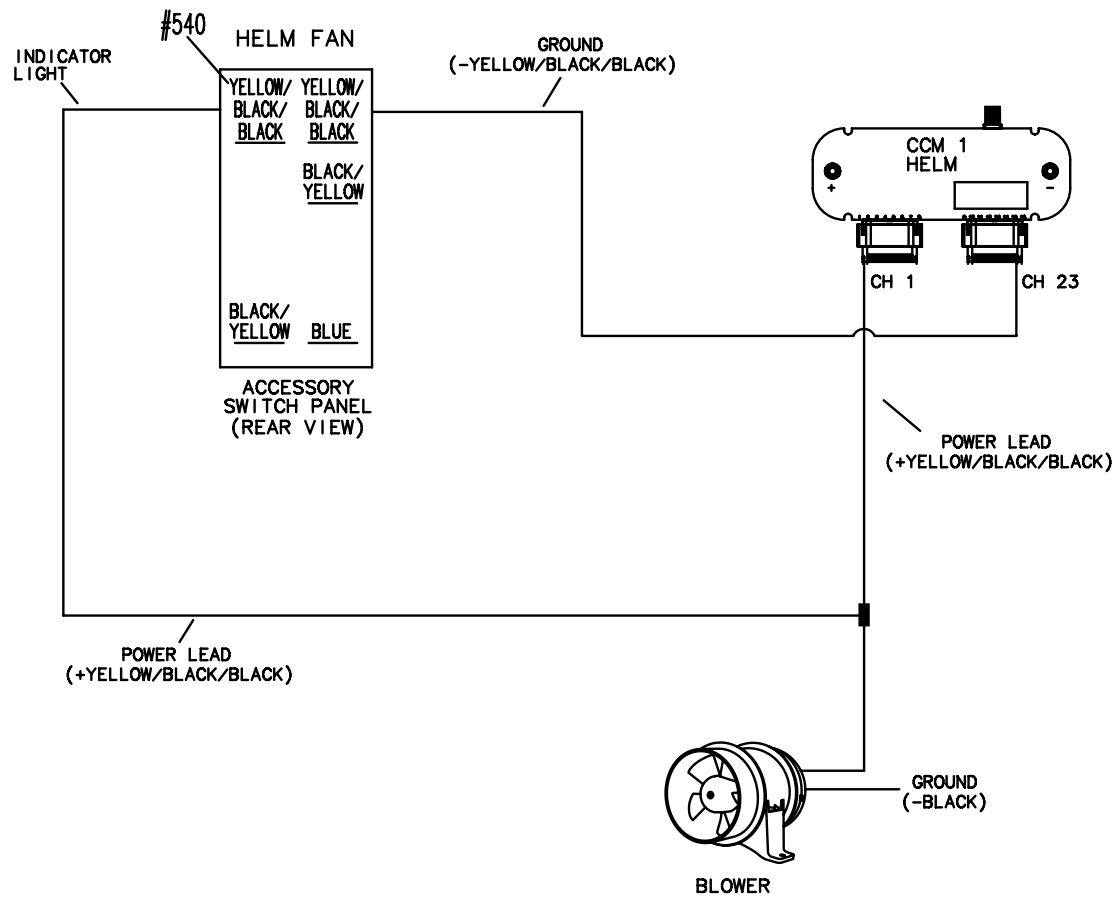

TITLE: AC BOOST DASH		THUNDERBIRD PRODUCTS
		P.O. BOX 1003
MOD.: 400 SSC	DR BY: KPP	DECATUR IN., 46733
NO.: 16	DATE: 10-5-18	(260) 724-9111

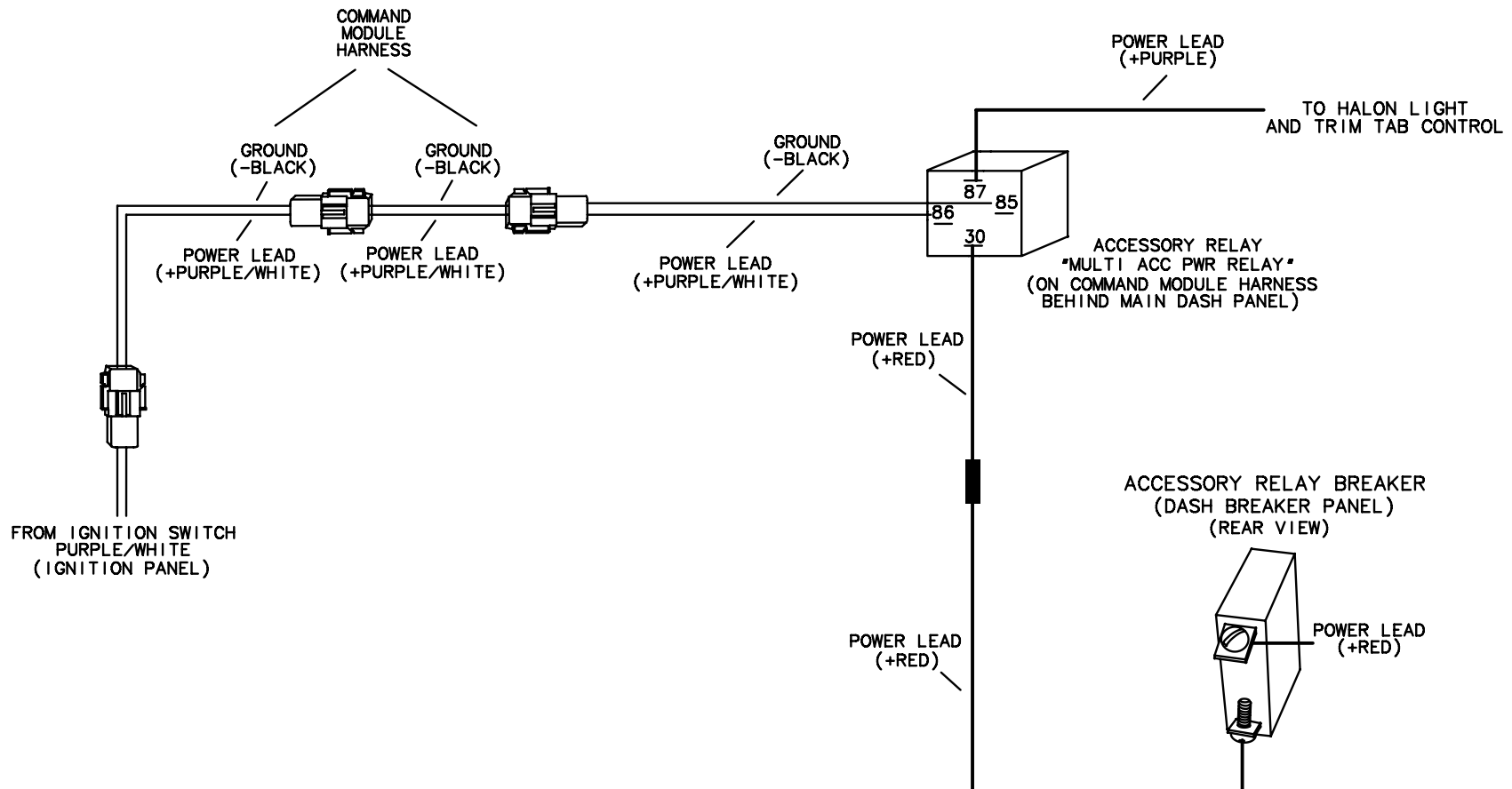

TITLE: ACCESSORY RELAY		THUNDERBIRD PRODUCTS
		P.O. BOX 1003
MOD.: 400 SSC	DR BY: KPP	DECATUR IN., 46733
NO.: 17	DATE:10-5-18	(260) 724-9111

LEGEND

C-BREAKER PANEL 

PLUG INTERCONNECT 

FIRE EXTINGUISH LIGHT 

CONNECTOR 

MANUAL RELEASE CABLE 

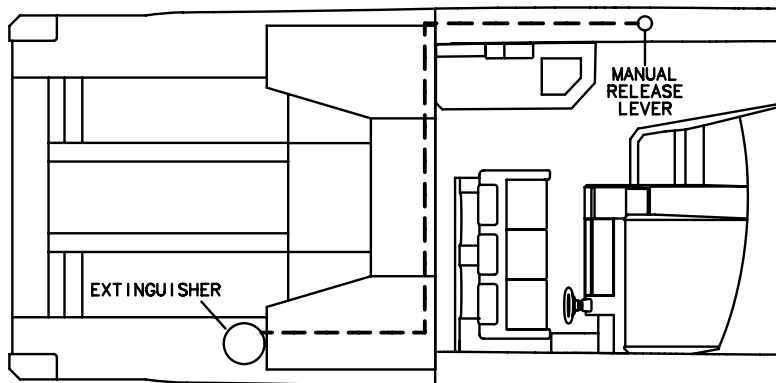
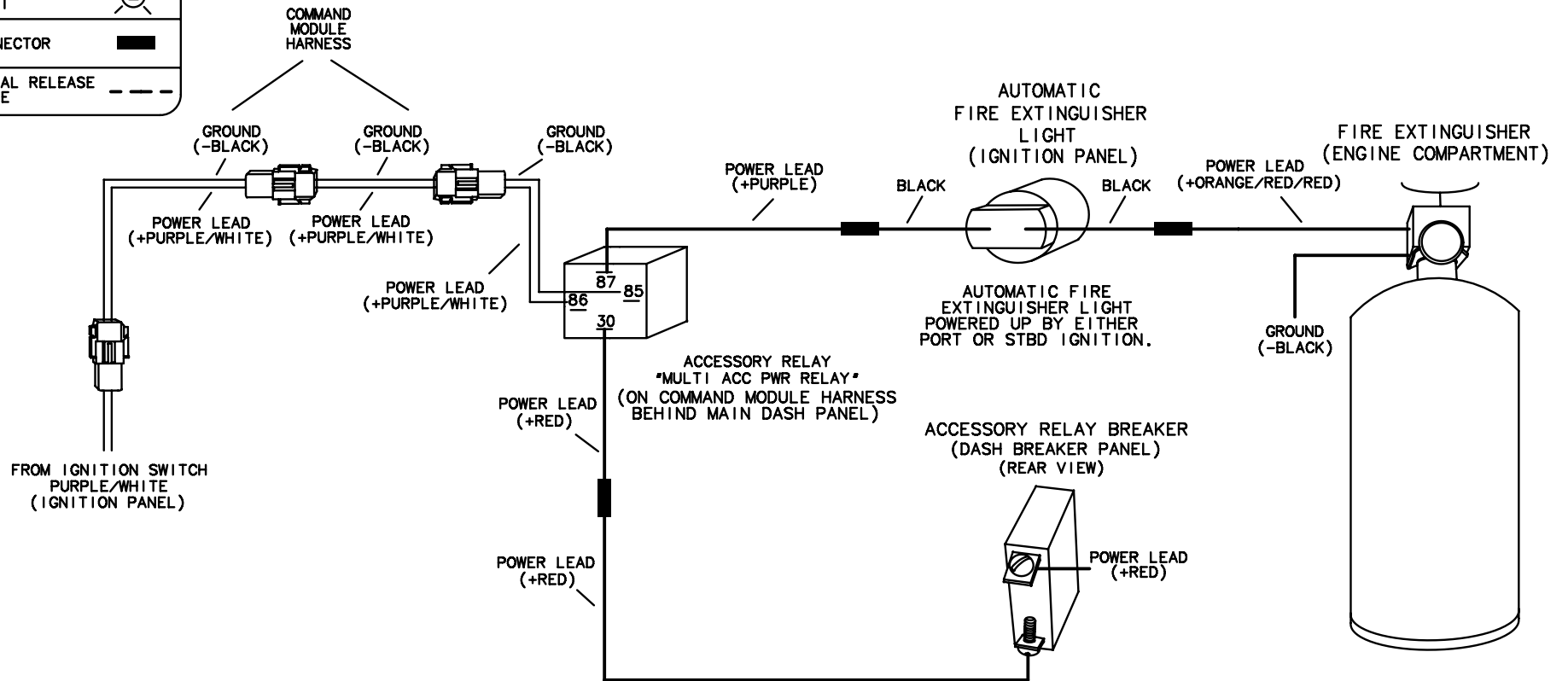

TITLE: AUTOMATIC FIRE EXTINGUISHER		THUNDERBIRD PRODUCTS
		P.O. BOX 1003
MOD.: 400 SSC	DR BY: KPP	DECATUR IN., 46733
NO.: 18	DATE: 10-5-18	(260) 724-9111

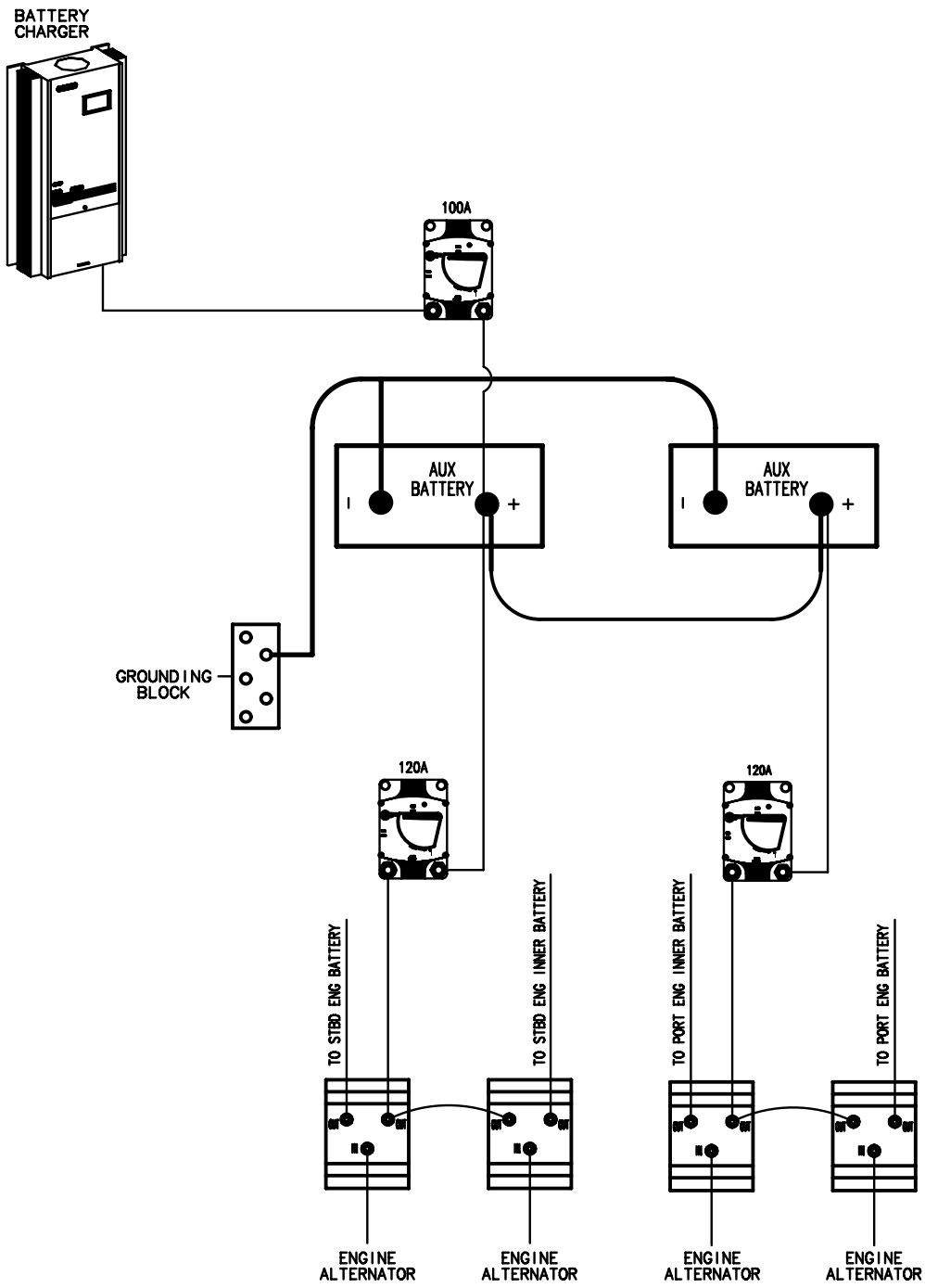

TITLE: BATTERY CHARGING SYS AUXILIARY BATTERIES		THUNDERBIRD PRODUCTS P.O. BOX 1003 DECATUR IN., 46733
MOD.: 400 SSC	DR BY: KPP	DATE: 10-5-18
NO.: 19		(260) 724-9111

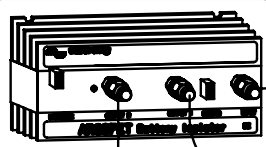
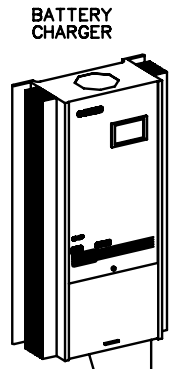

FROM STBD ENG ISO

FROM STBD ENG INNER ISO

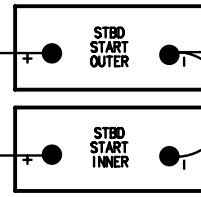

TO GROUND BLOCK



FROM PORT ENG INNER ISO

FROM PORT ENG ISO

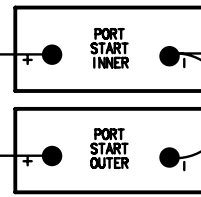

TO GROUND BLOCK

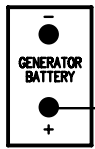

TITLE: BATTERY CHARGING START/GEN BATTERIES		THUNDERBIRD PRODUCTS
		P.O. BOX 1003
MOD.: 400 SSC	DR BY: KPP	DECATUR IN., 46733
NO.: 20	DATE: 10-5-18	(260) 724-9111

LEGEND

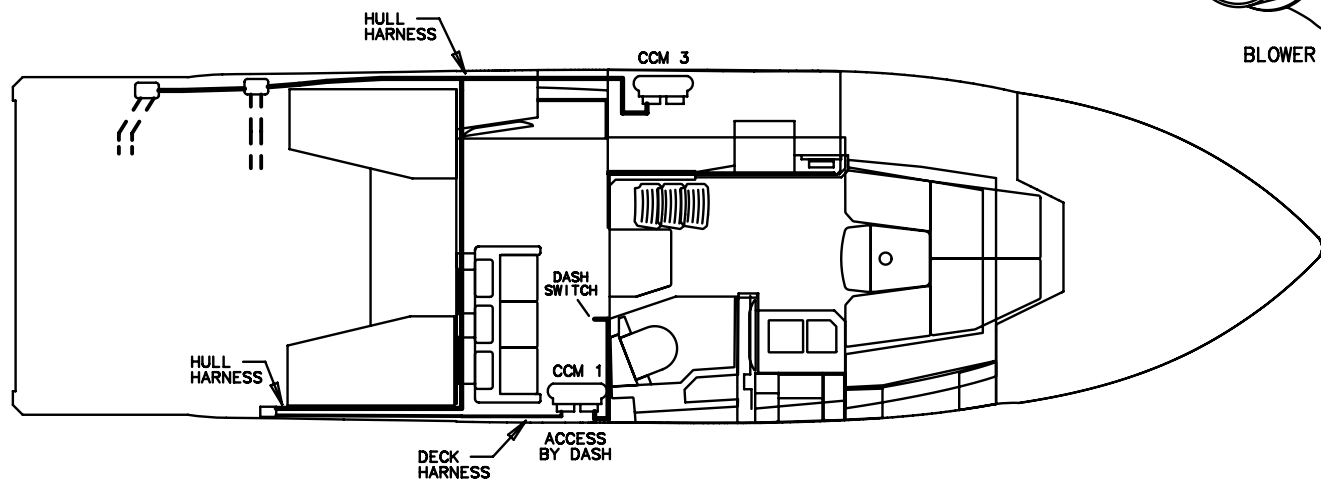
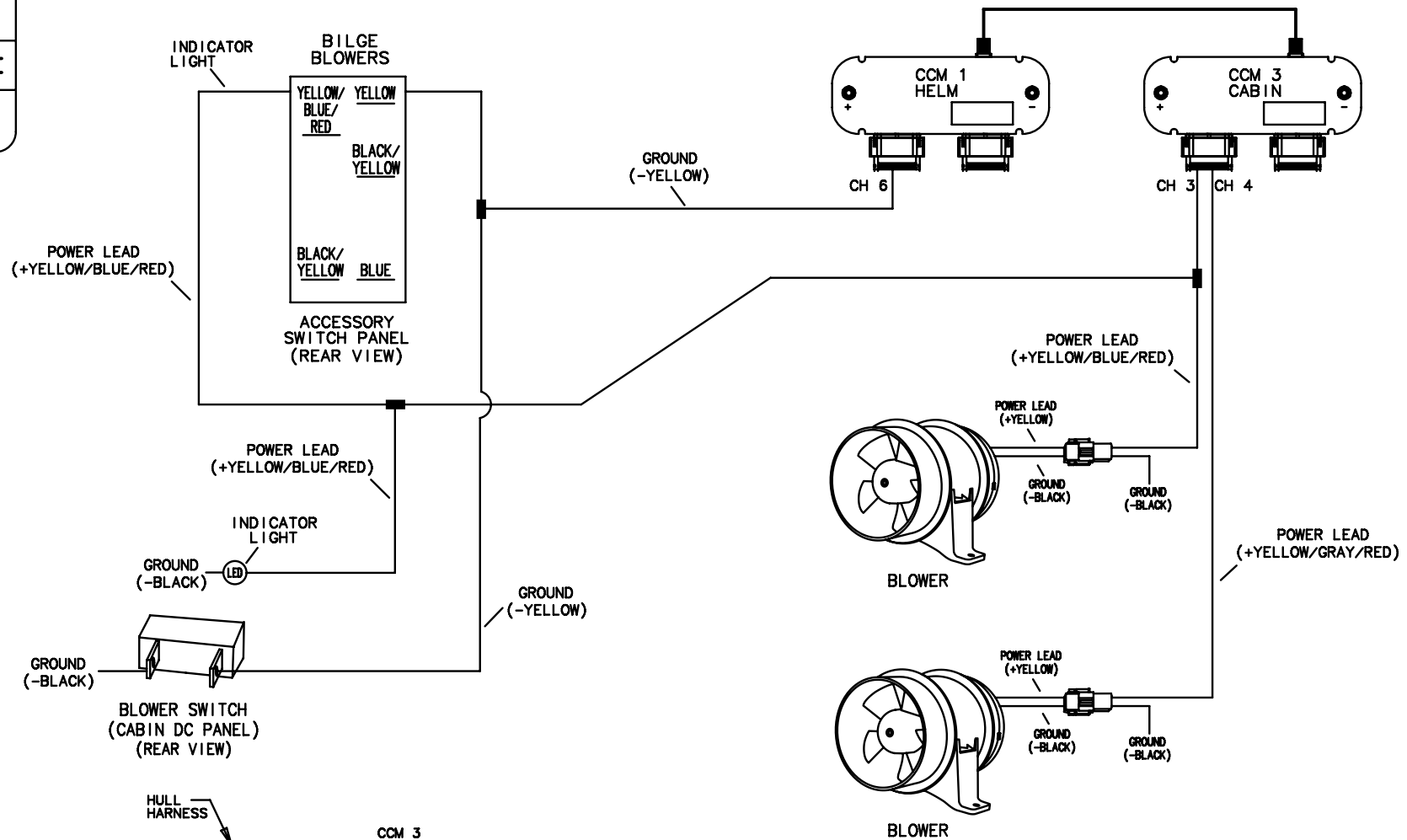
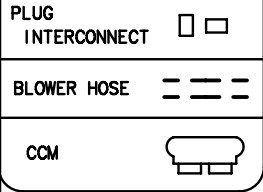

TITLE: BILGE BLOWERS		THUNDERBIRD PRODUCTS
		P.O. BOX 1003
MOD.: 400 SSC	DR BY: KPP	DECATUR IN., 46733
NO.: 21	DATE: 10-5-18	(260) 724-9111

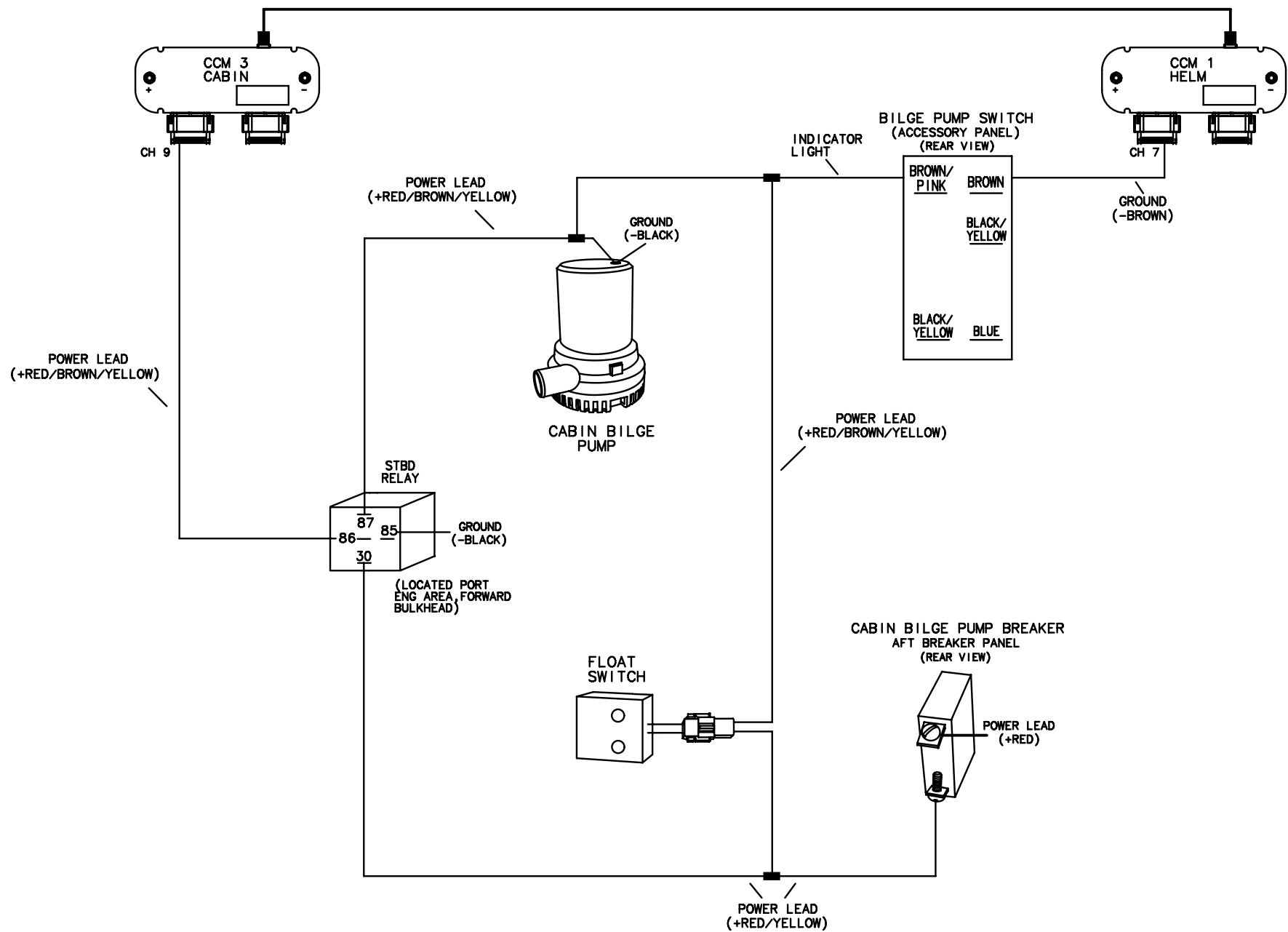

TITLE: BILGE PUMP, CABIN		THUNDERBIRD PRODUCTS
		P.O. BOX 1003
MOD.: 400 SSC	DR BY: KPP	DECATUR IN., 46733
NO.: 22	DATE:10-5-18	(260) 724-9111

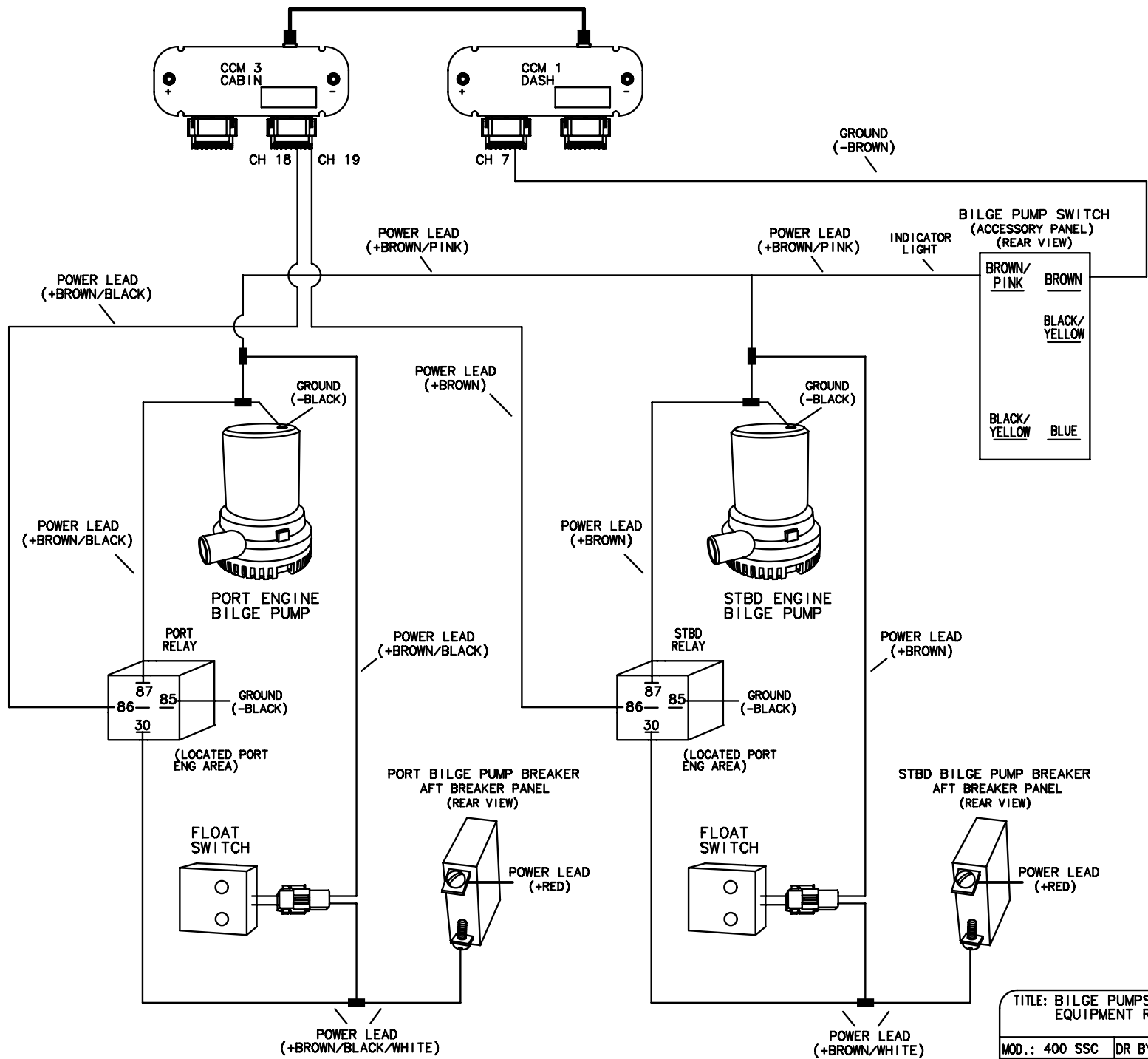

TITLE: BILGE PUMPS, EQUIPMENT ROOM		THUNDERBIRD PRODUCTS
		P.O. BOX 1003
MOD.: 400 SSC	DR BY: KPP	DECATUR IN., 46733
NO.: 23	DATE: 10-5-18	(260) 724-9111

NOTE:
ALL BONDING WIRES ARE LIGHT GREEN.

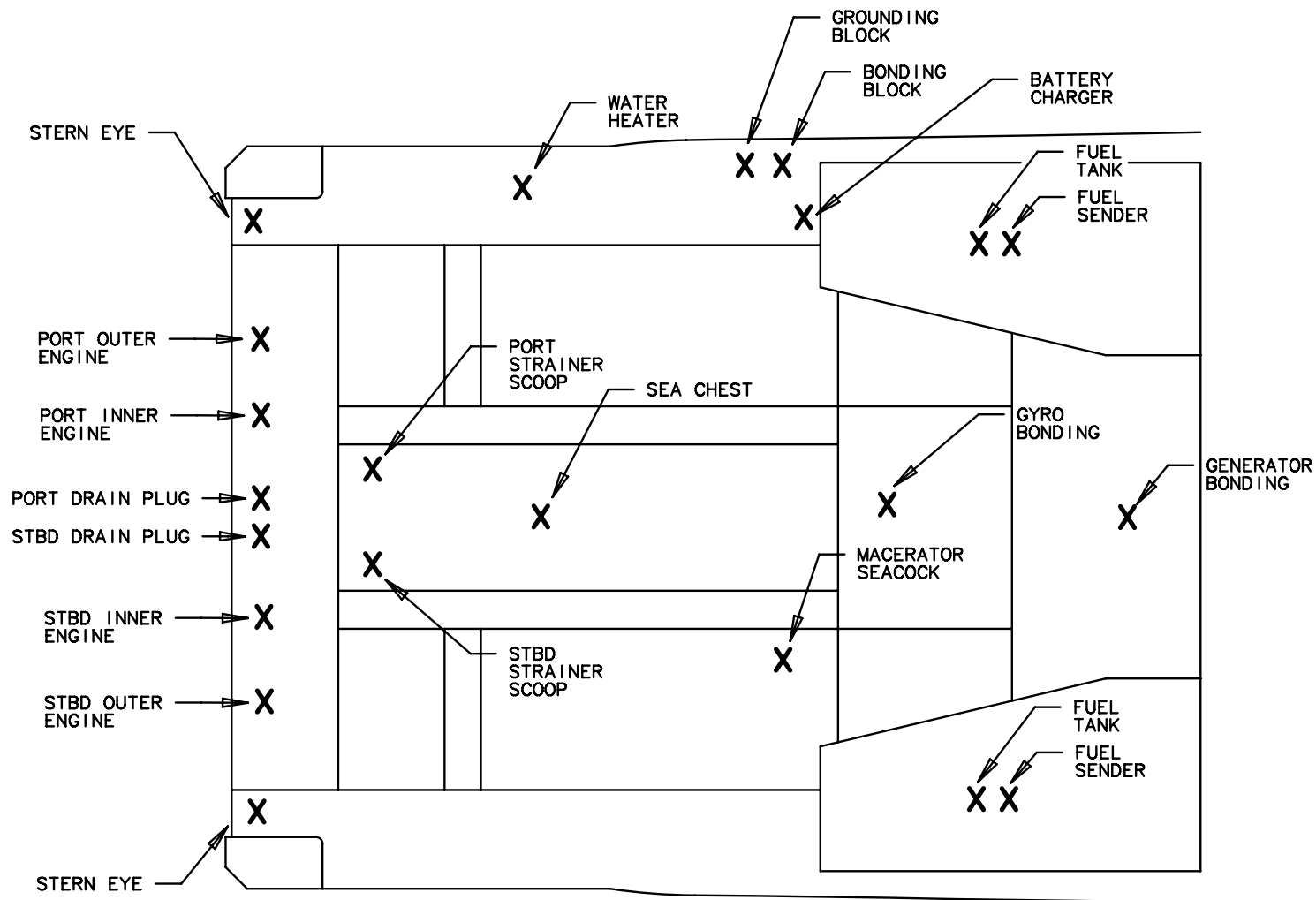

TITLE: BONDING		THUNDERBIRD PRODUCTS
		P.O. BOX 1003
MOD.: 400 SSC	DR BY: KPP	DECATUR IN., 46733
NO.: 24	DATE: 10-5-18	(260) 724-9111

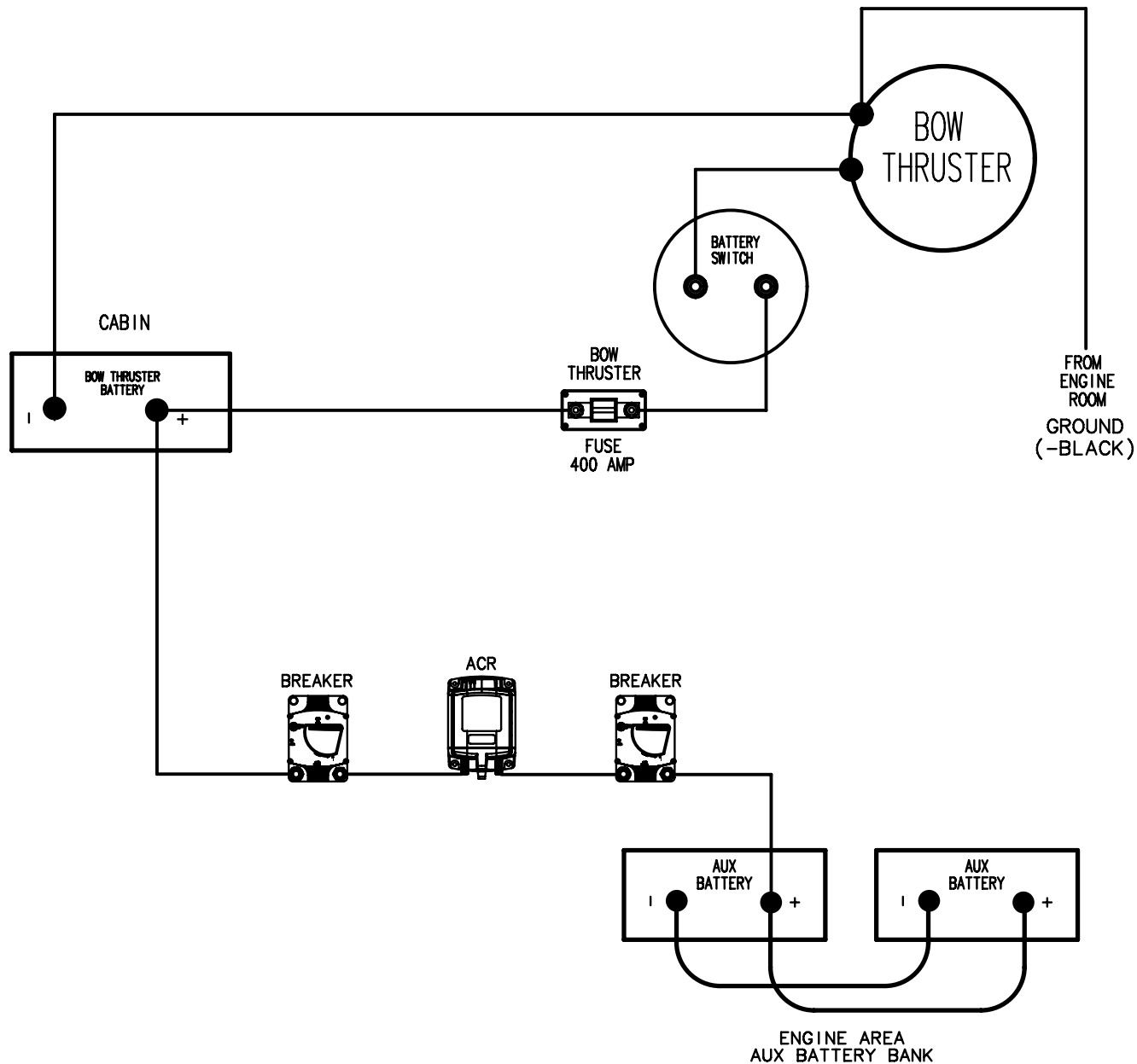

TITLE: BOW THRUSTER		THUNDERBIRD PRODUCTS
		P.O. BOX 1003
MOD.: 400 SSC	DR BY: KPP	DECATUR IN., 46733
NO.: 25	DATE: 10-5-18	(260) 724-9111

CO DETECTOR BREAKER
(CABIN 12V BREAKER PANEL)
(REAR VIEW)

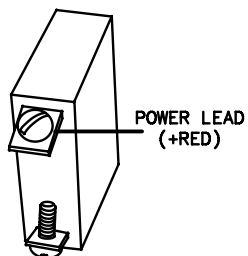

CO DETECTOR
(REAR VIEW)

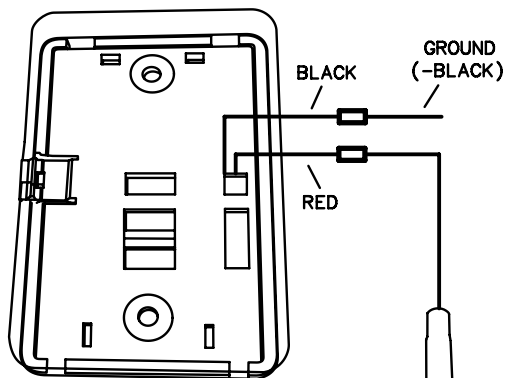

CO DETECTOR
(FRONT VIEW)

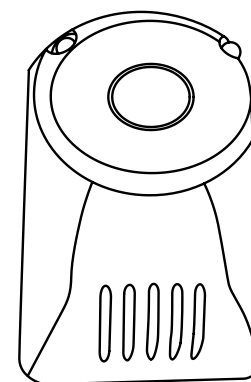

POWER LEAD
(+ORANGE/BROWN)

1 AMP FUSE

TITLE: CARBON MONOXIDE DETECTOR		THUNDERBIRD PRODUCTS
		P.O. BOX 1003
MOD.: 400 SSC	DR BY: KPP	DECATUR IN., 46733
NO.: 26	DATE: 10-5-18	(260) 724-9111

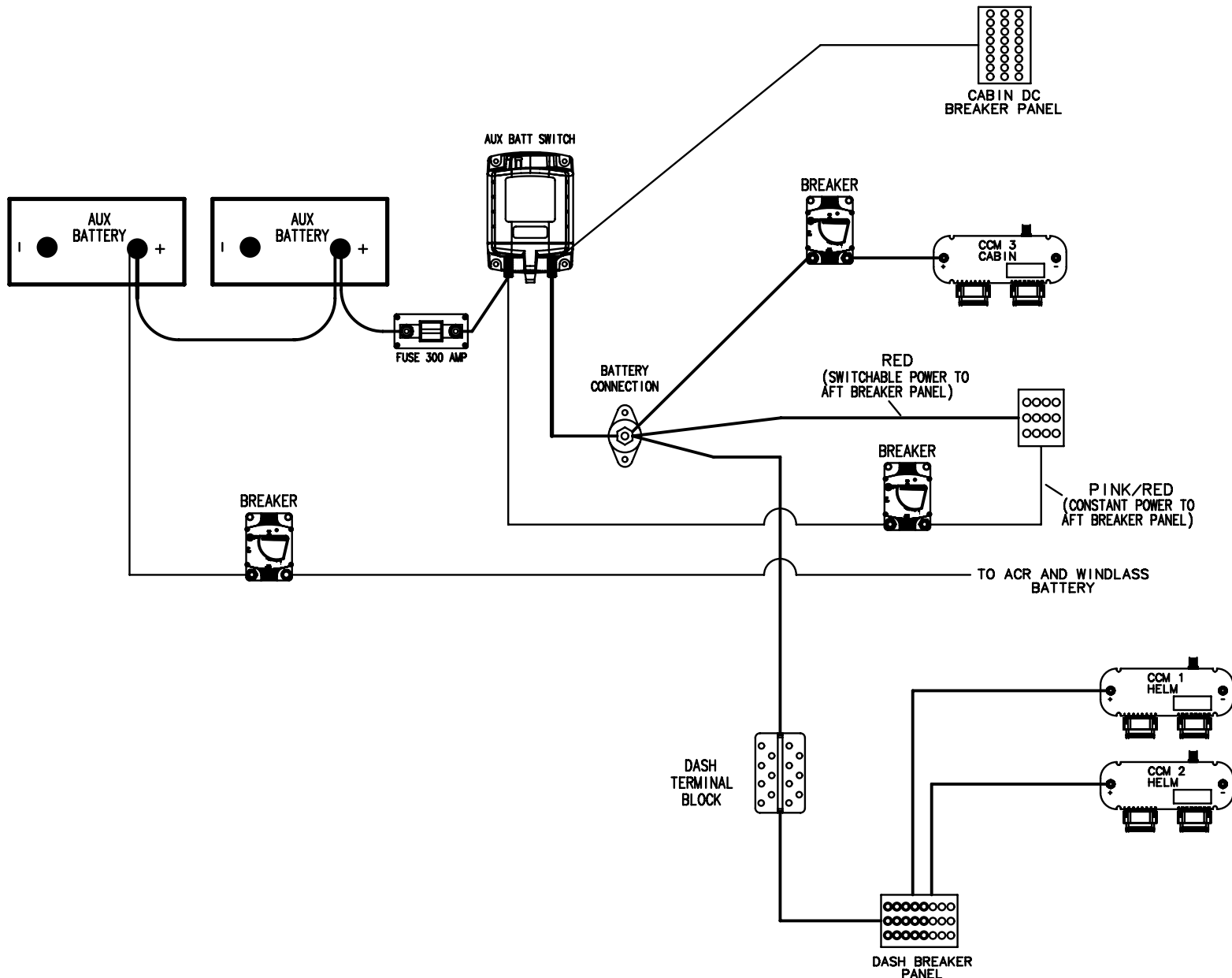

TITLE: DC DISTRIBUTION		THUNDERBIRD PRODUCTS
		P.O. BOX 1003
MOD.: 400 SSC	DR BY: KPP	DECATUR IN., 46733
NO.: 27	DATE:10-5-18	(260) 724-9111

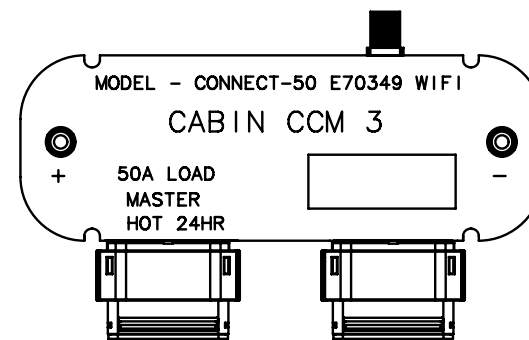
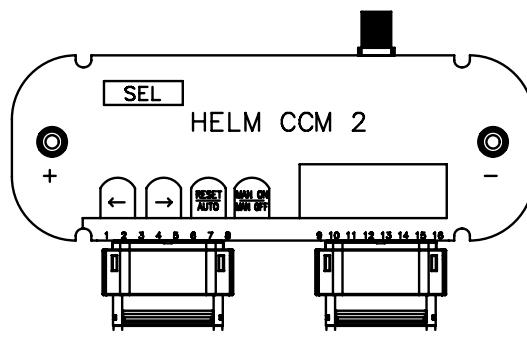
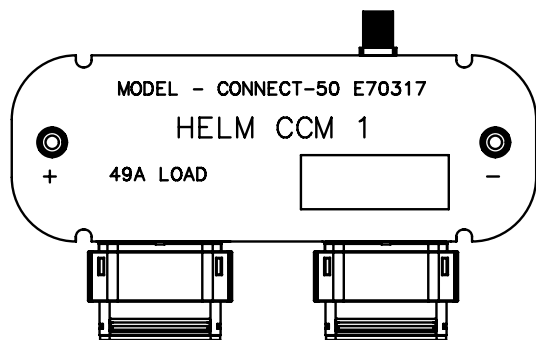

A CHANNEL WITH A TRIPPED BREAKER IS INDICATED BY A RED CONTINUOUS CHANNEL LIGHT.
TO RESET THE CHANNEL TO NORMAL OPERATION:

1. PRESS THE RIGHT ARROW BUTTON, "SEL" WILL BE SHOWN ON THE DISPLAY.
2. USE THE RIGHT ARROW BUTTON TO SELECT THE DESIRED CHANNEL.
3. PRESS AND HOLD RESET/AUTO FOR TWO SECONDS. THE BREAKER IS NOW RESET.
4. PRESS THE LEFT ARROW UNTIL THE MESSAGE "SEL" IN THE DISPLAY DISAPPEARS.

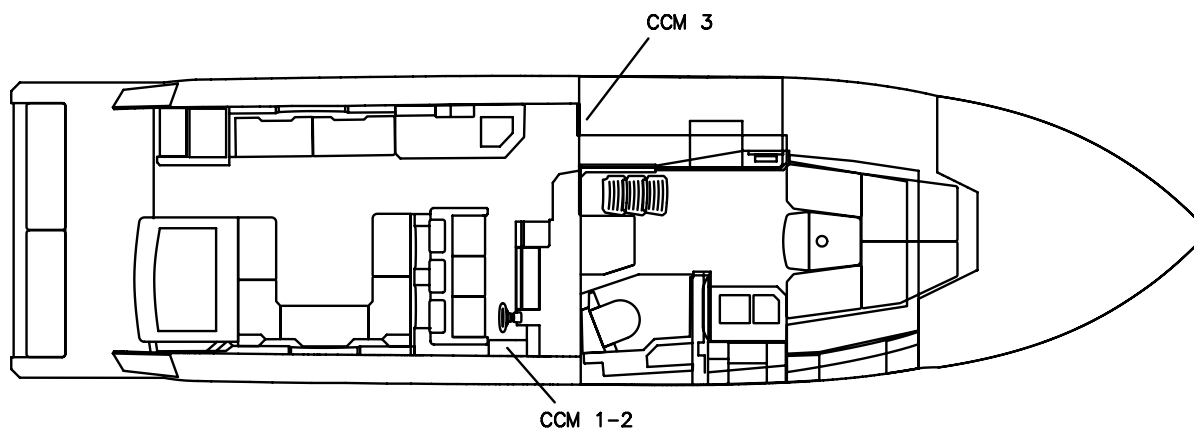

TITLE: DIGITAL SWITCHING BREAKER RESET		THUNDERBIRD PRODUCTS
		P.O. BOX 1003
MOD.: 400 SSC	DR BY: KPP	DECATUR IN., 46733
NO.: 28	DATE:10-5-18	(260) 724-9111

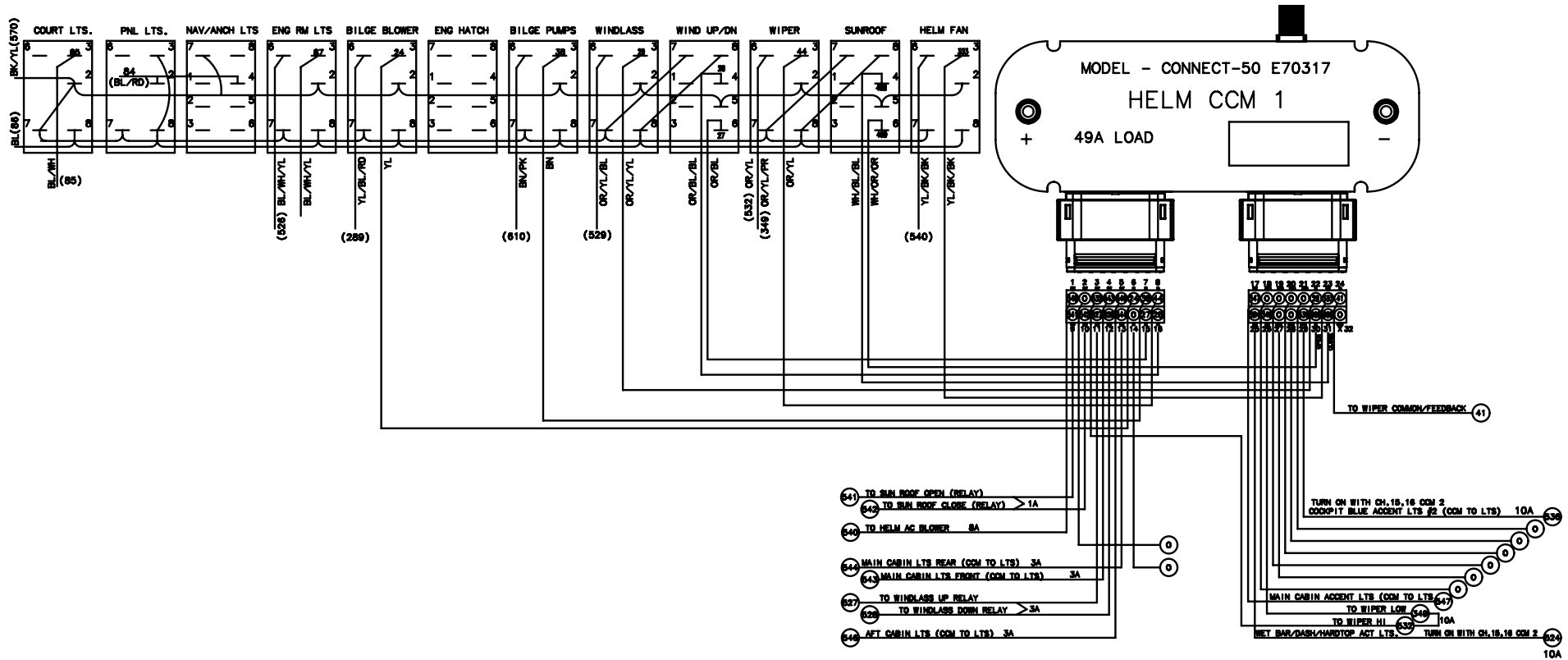

TITLE: DIGITAL SWITCHING, CCM 1		THUNDERBIRD PRODUCTS
		P.O. BOX 1003
MOD.: 400 SSC	DR BY: KPP	DECATUR IN., 46733
NO.: 29	DATE: 10-5-18	(260) 724-9111

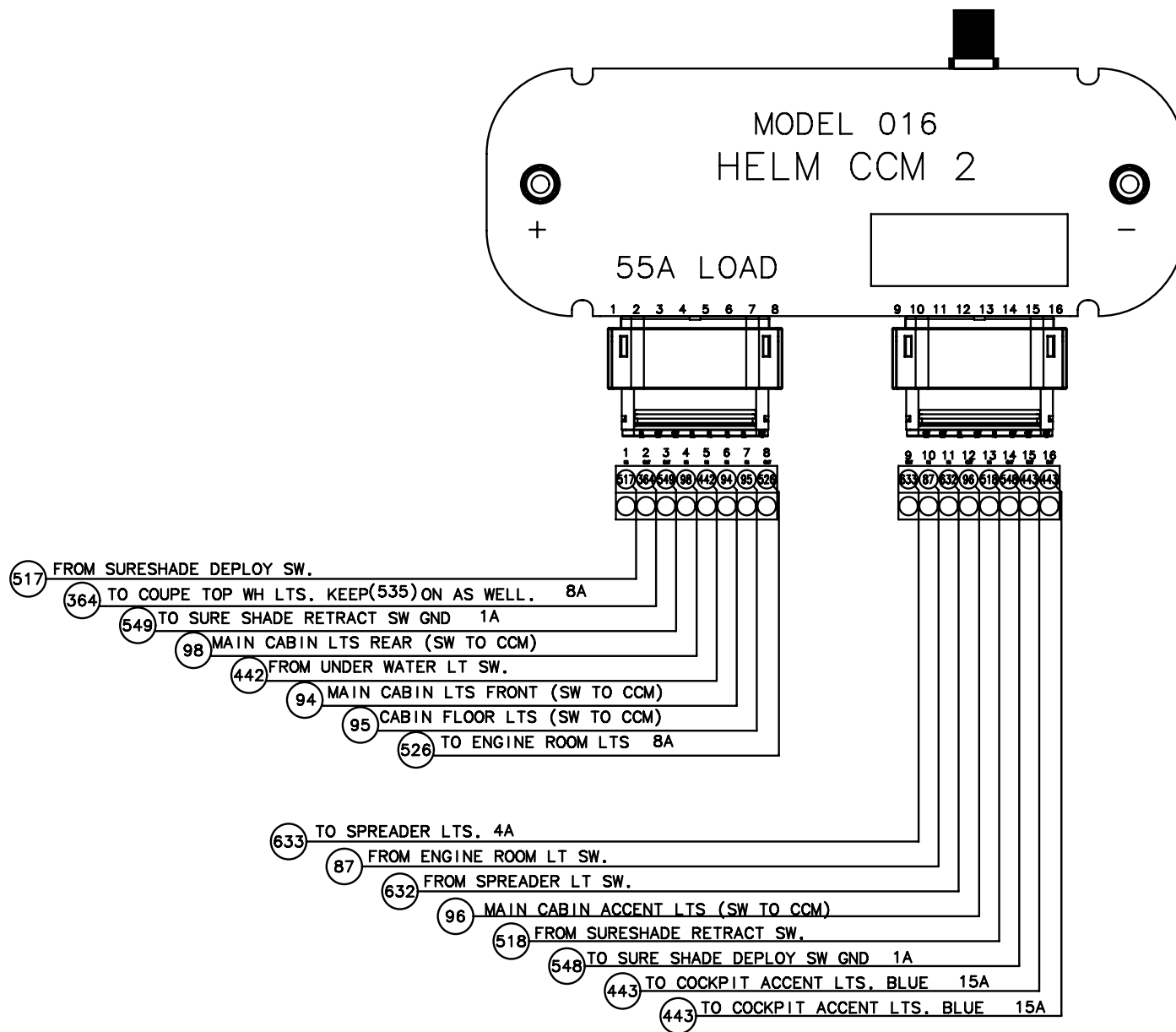

TITLE: DIGITAL SWITCHING, CCM 2		THUNDERBIRD PRODUCTS
		P.O. BOX 1003
MOD.: 400 SSC	DR BY: KPP	DECATUR IN., 46733
NO.: 30	DATE: 10-5-18	(260) 724-9111

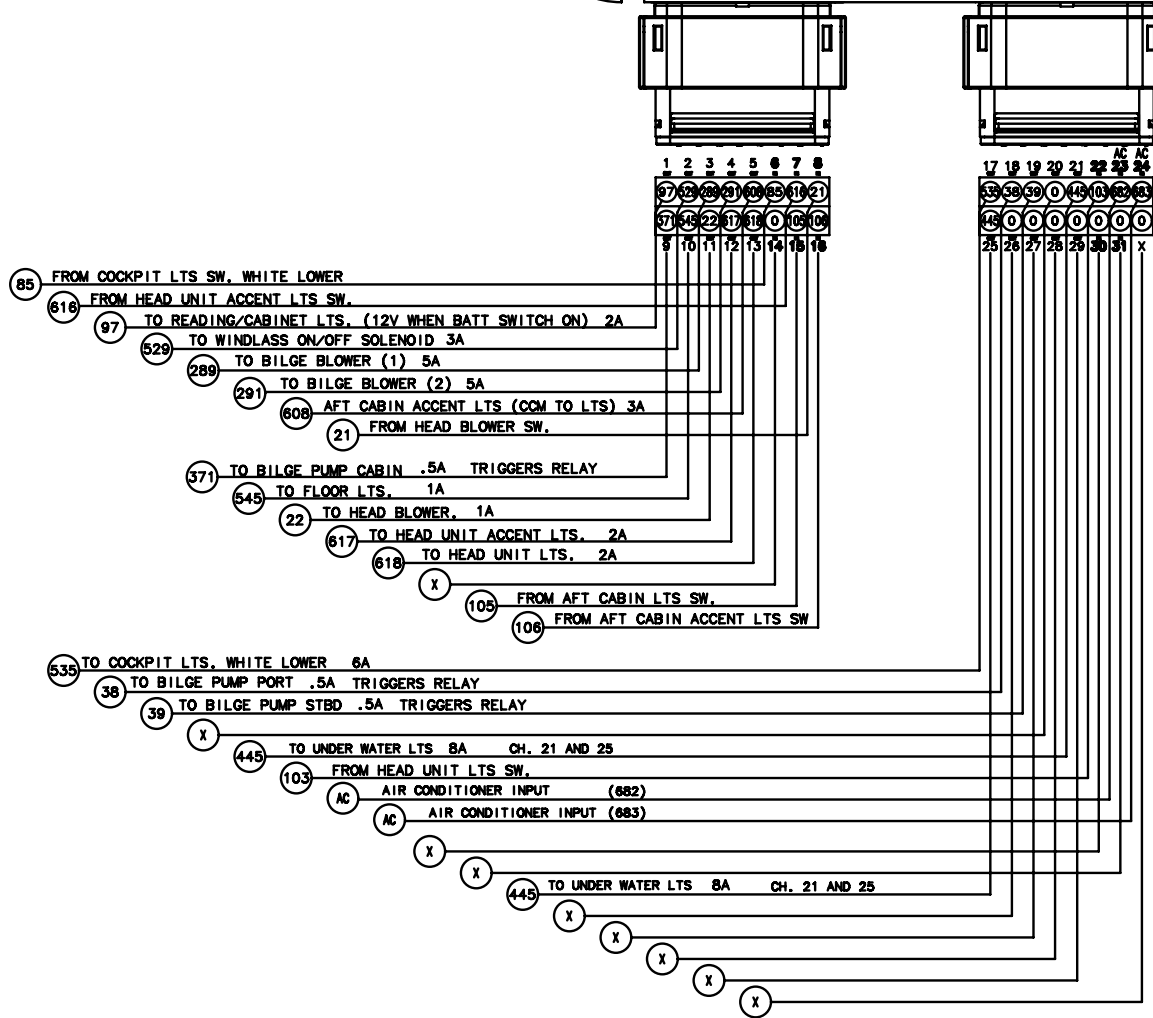
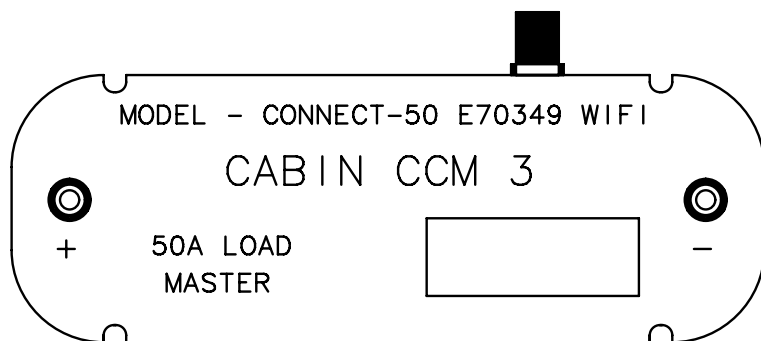

TITLE: DIGITAL SWITCHING, CCM 3		THUNDERBIRD PRODUCTS
		P.O. BOX 1003
MOD.: 400 SSC	DR BY: KPP	DECATUR IN., 46733
NO.: 31	DATE: 10-5-18	(260) 724-9111

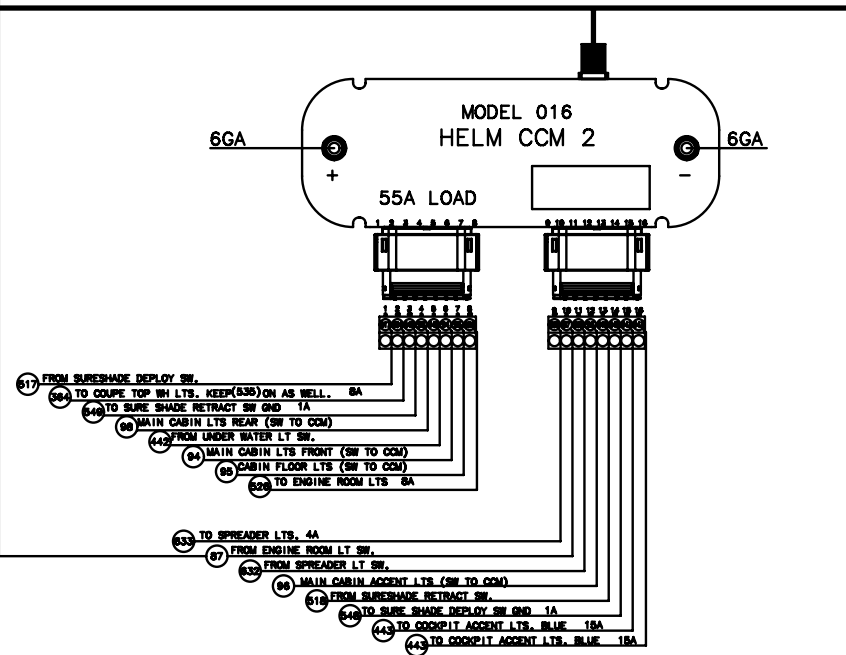
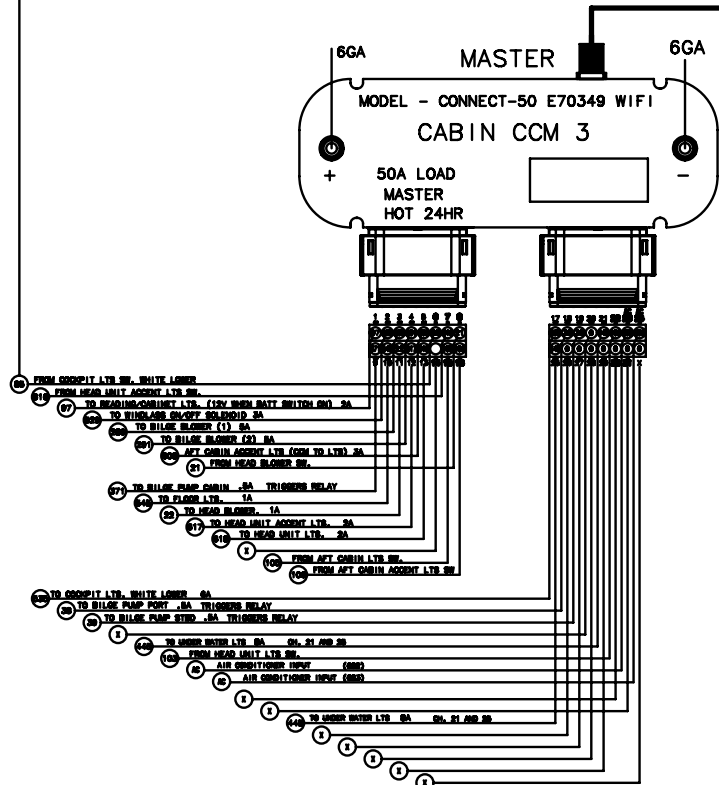
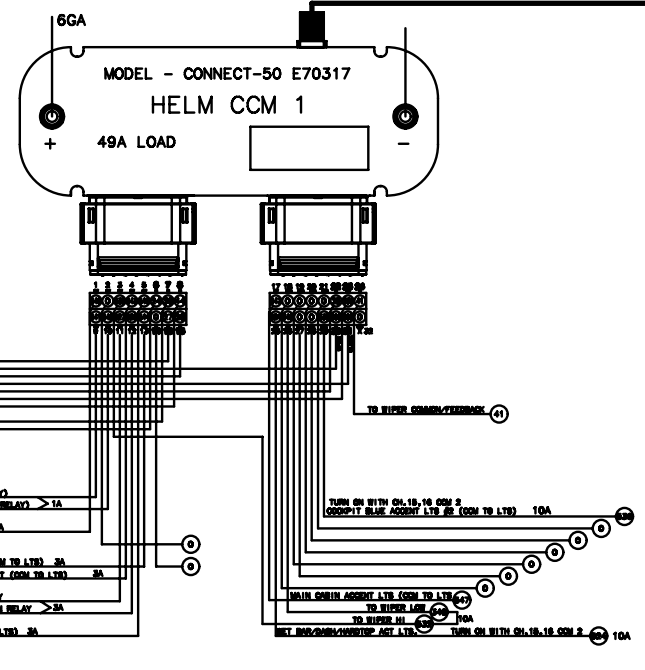
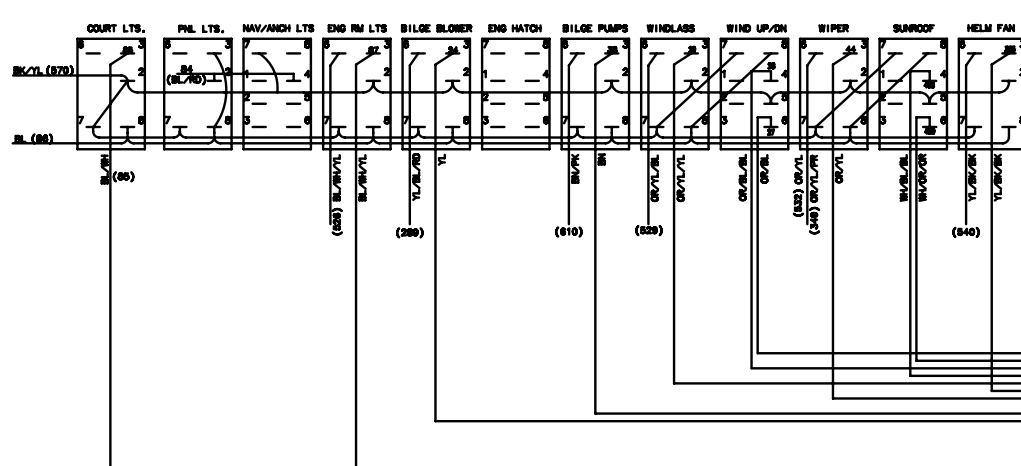

TITLE: DIGITAL SWITCHING OVERVIEW		THUNDERBIRD PRODUCTS	
		P.O. BOX 1003	
MOD.: 400 SSC	DR BY: KPP	DECATUR IN., 46733	
NO.: 32	DATE: 10-5-18	(260) 724-9111	

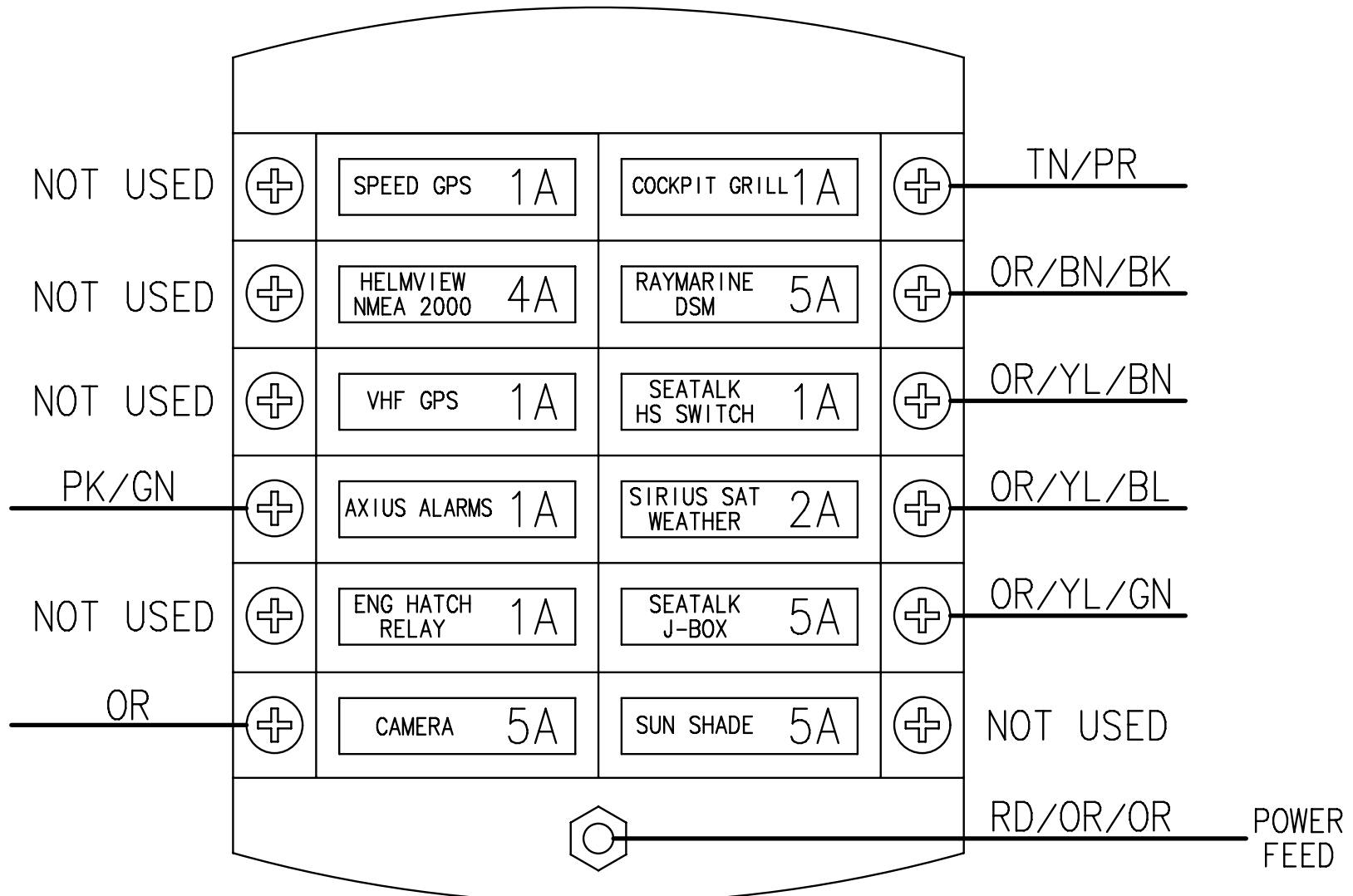

(UNDER DASH)

TITLE: ELECTRICAL FUSE BLOCK		THUNDERBIRD PRODUCTS
		P.O. BOX 1003
MOD.: 400 SSC	DR BY: KPP	DECATUR IN., 46733
NO.: 33	DATE: 10-5-18	(260) 724-9111

LEGEND

C-BREAKER
PANEL



WATER LINE



PLUG
INTERCONNECT

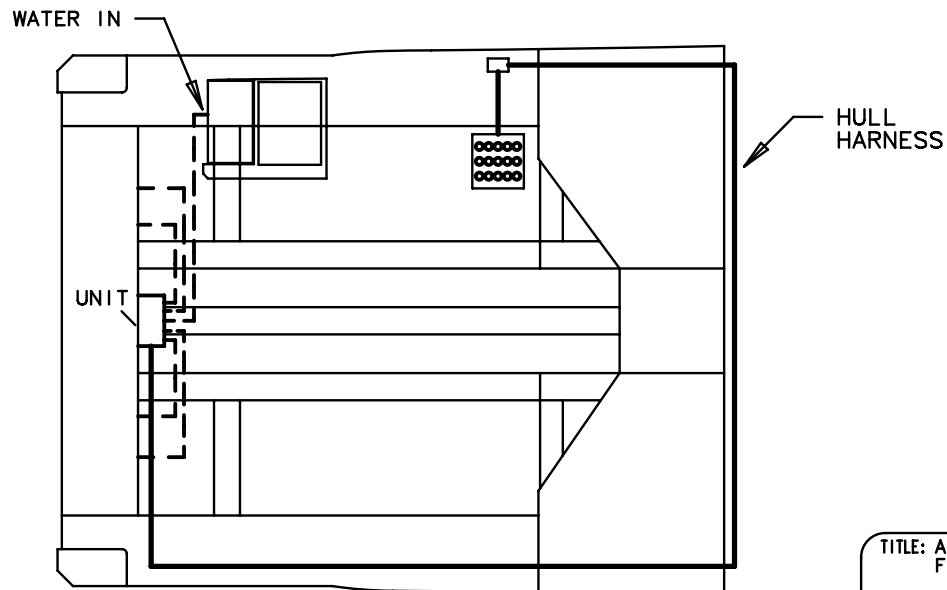
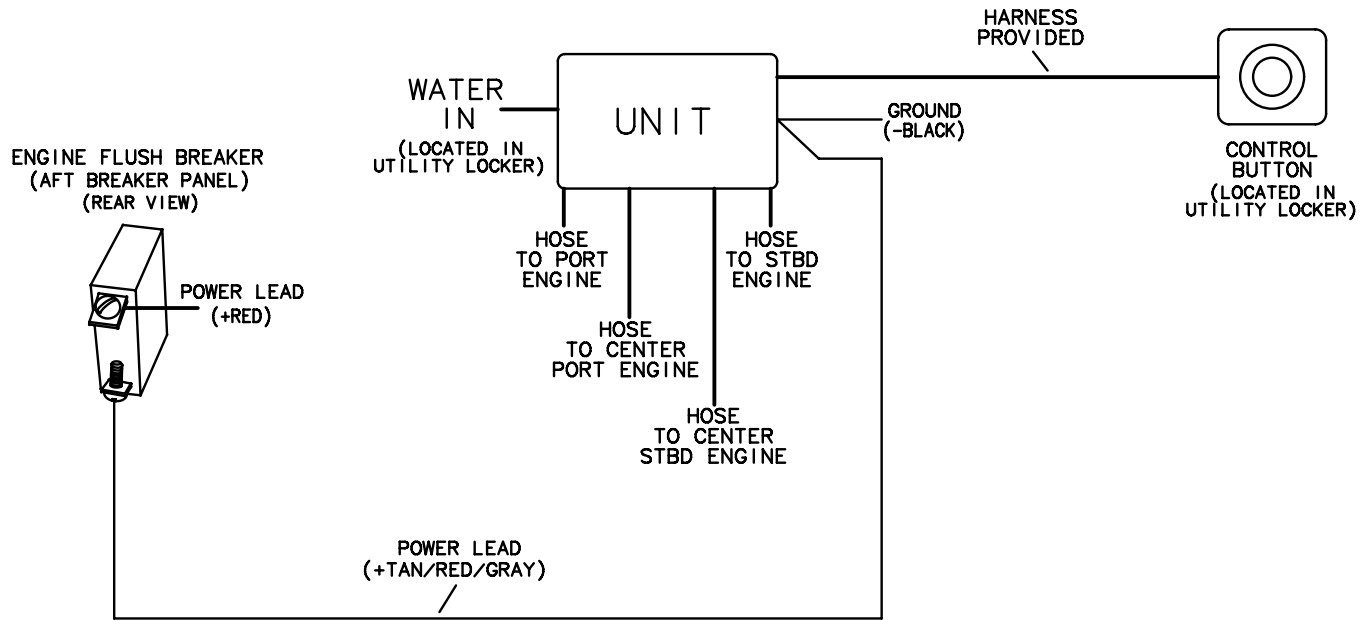

TITLE: AUTO OUTBOARD FLUSH SYSTEM		THUNDERBIRD PRODUCTS
		P.O. BOX 1003
MOD.: 400 SSC	DR BY: KPP	DECATUR IN., 46733
NO.: 34	DATE: 10-5-18	(260) 724-9111

LEGEND

C-BREAKER
PANEL



PLUG
INTERCONNECT

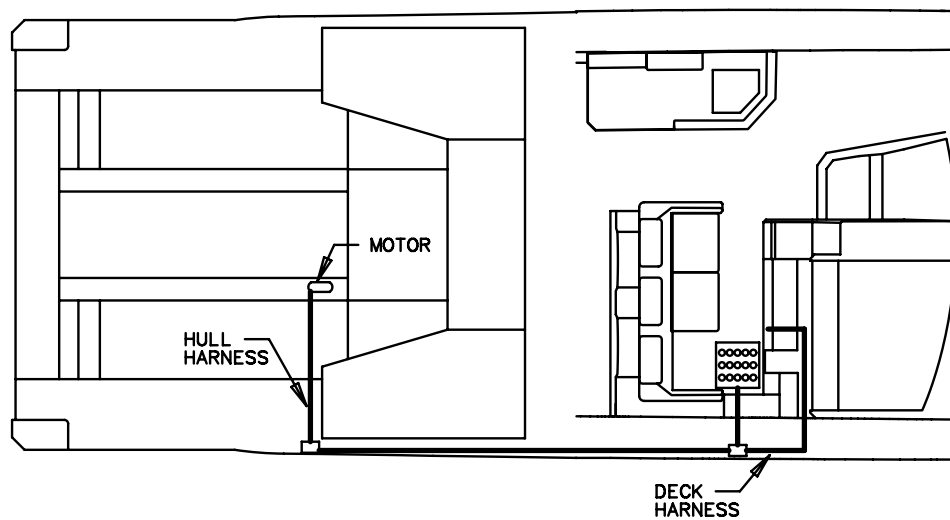
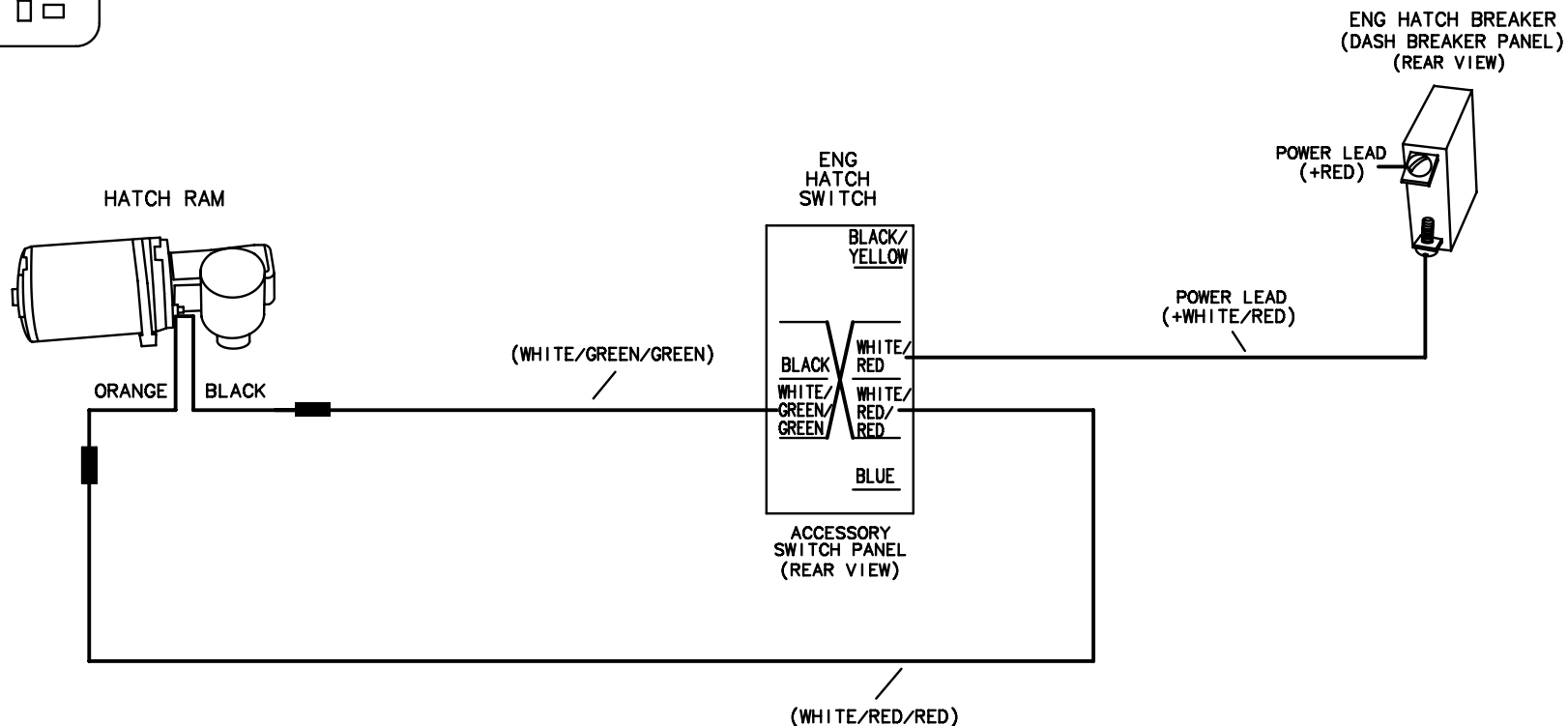

TITLE: EQUIPMENT ROOM HATCH RAM		THUNDERBIRD PRODUCTS P.O. BOX 1003 DECATUR IN., 46733
MOD.: 400 SSC	DR BY: KPP	DATE: 10-5-18
NO.: 35		(260) 724-9111

LEGEND

C-BREAKER PANEL 

GRAY FUME SENSOR CABLE 

PLUG INTERCONNECT 

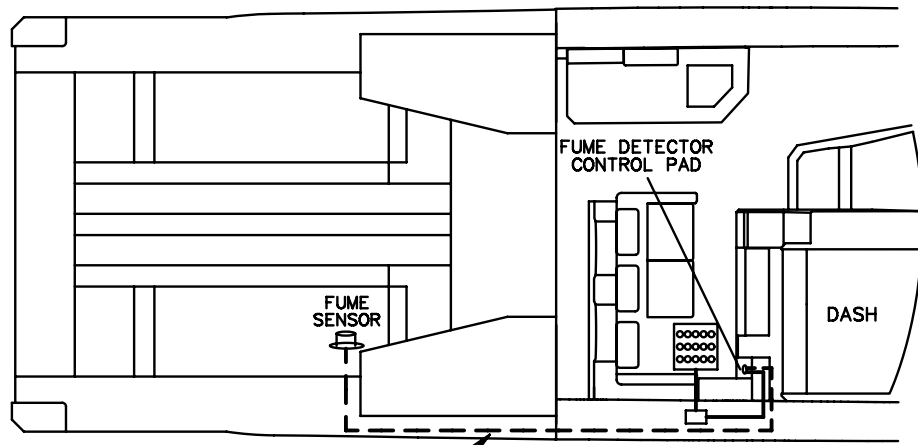
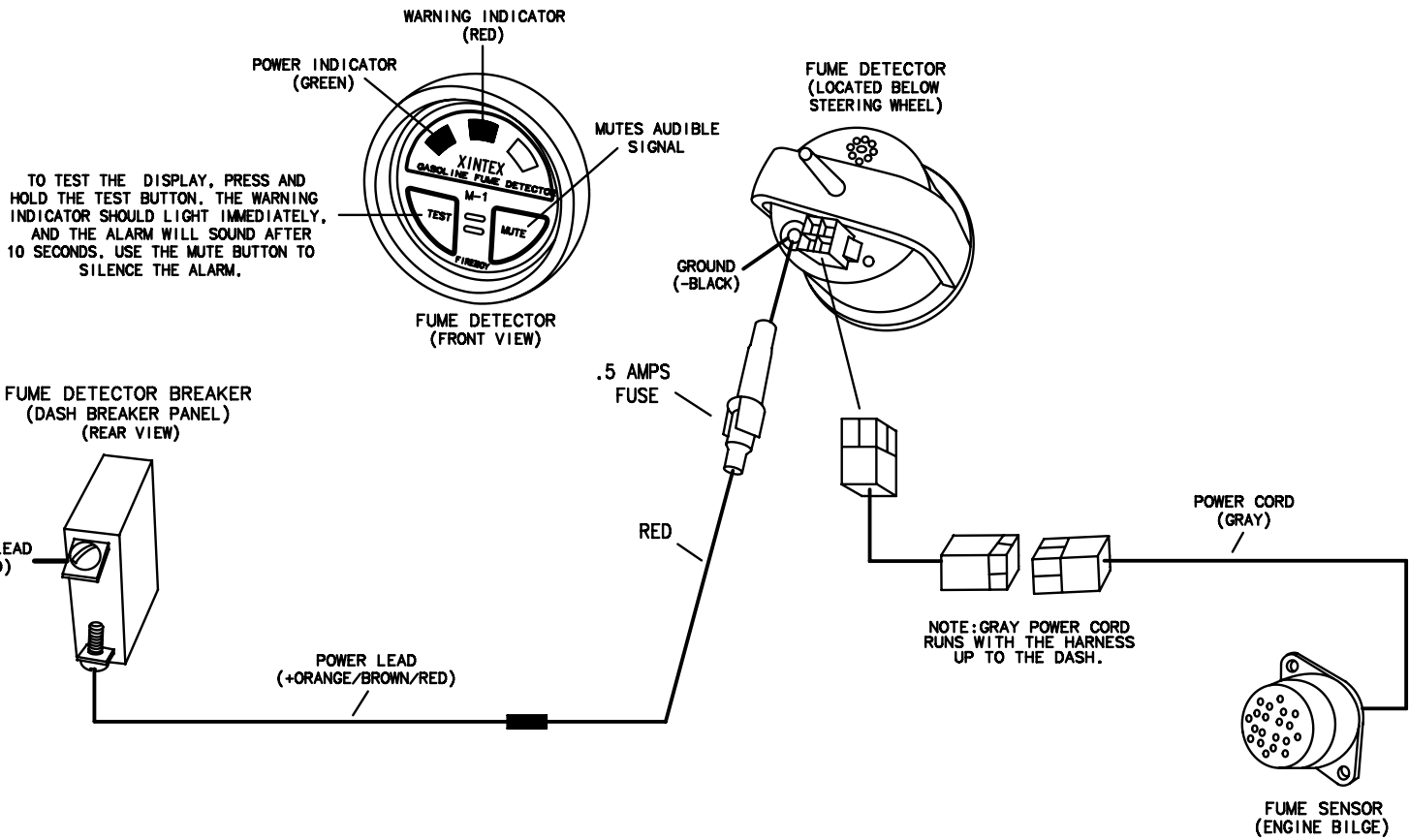

RUNS WITH HULL HARNESS,
THEN WITH DECK HARNESS

TITLE: FUME DETECTOR		THUNDERBIRD PRODUCTS
		P.O. BOX 1003
MOD.: 400 SSC	DR BY: KPP	DECATUR IN., 46733
NO.: 36	DATE: 10-5-18	(260) 724-9111

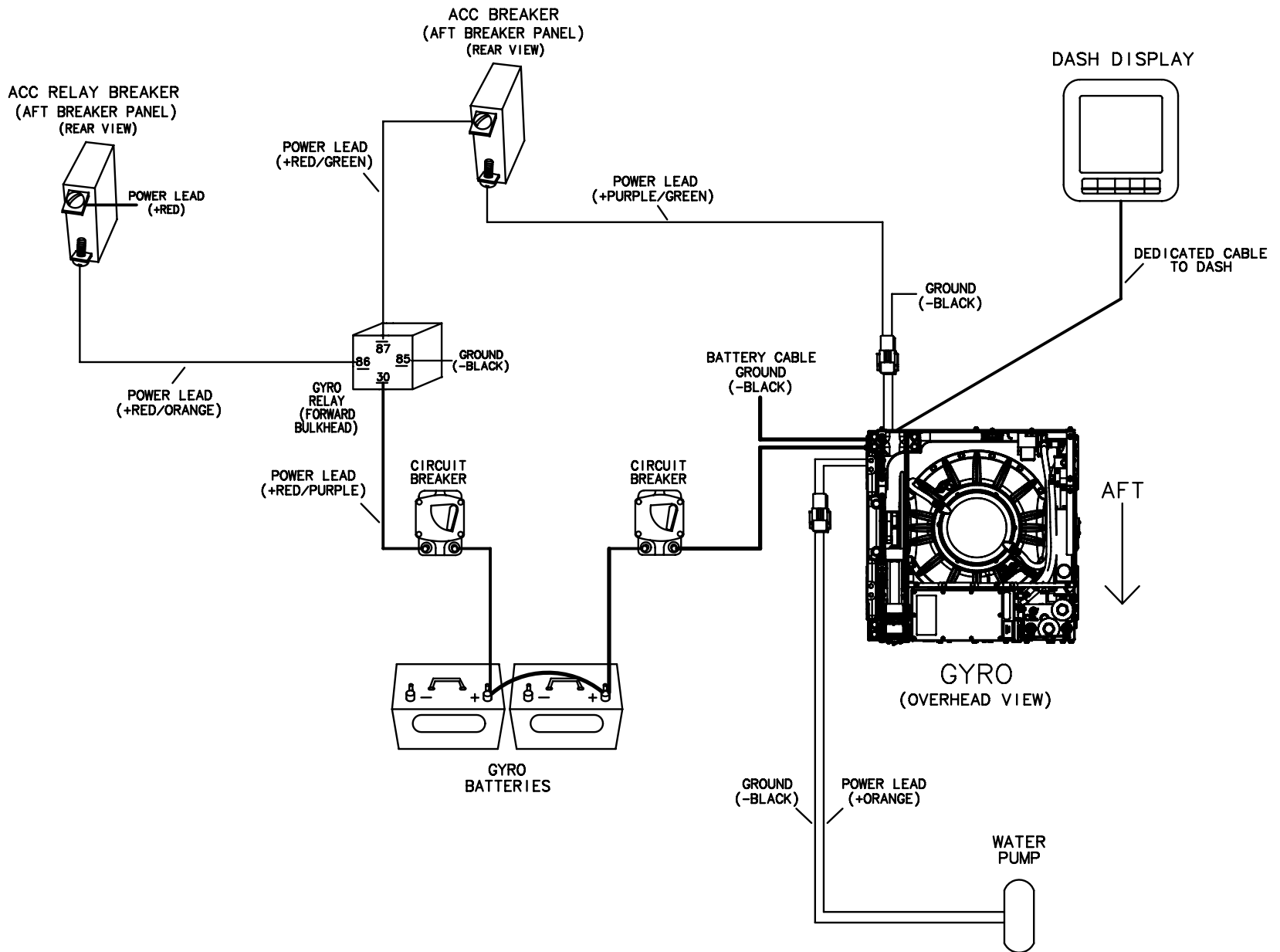

TITLE: GYRO STABILIZER, SEAKEEPER 3		THUNDERBIRD PRODUCTS
		P.O. BOX 1003
MOD.: 400 SSC	DR BY: KPP	DECATUR IN., 46733
NO.: 37	DATE: 10-5-18	(260) 724-9111

LEGEND

PLUG INTERCONNECT 

CCM 

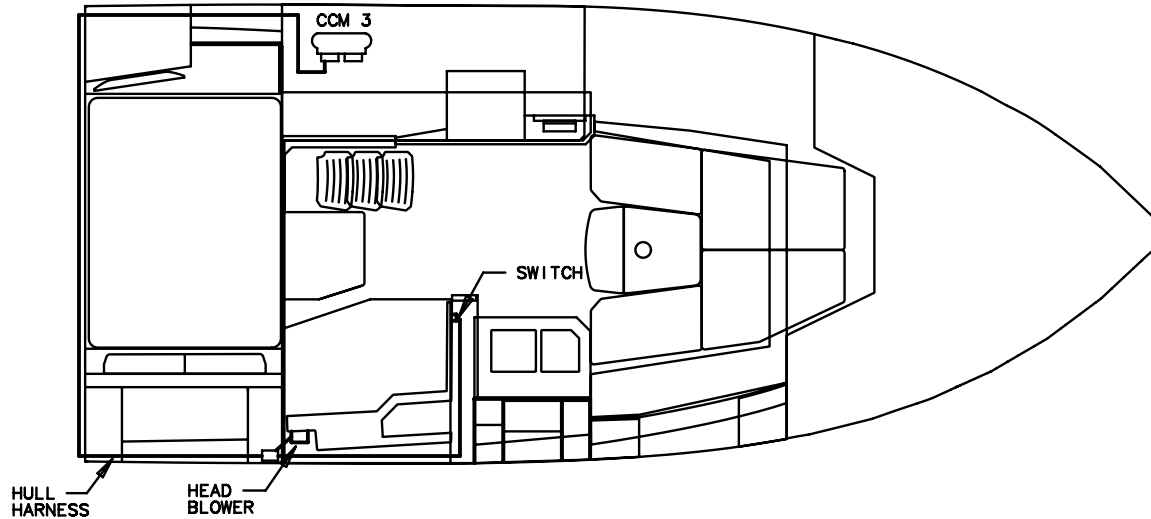
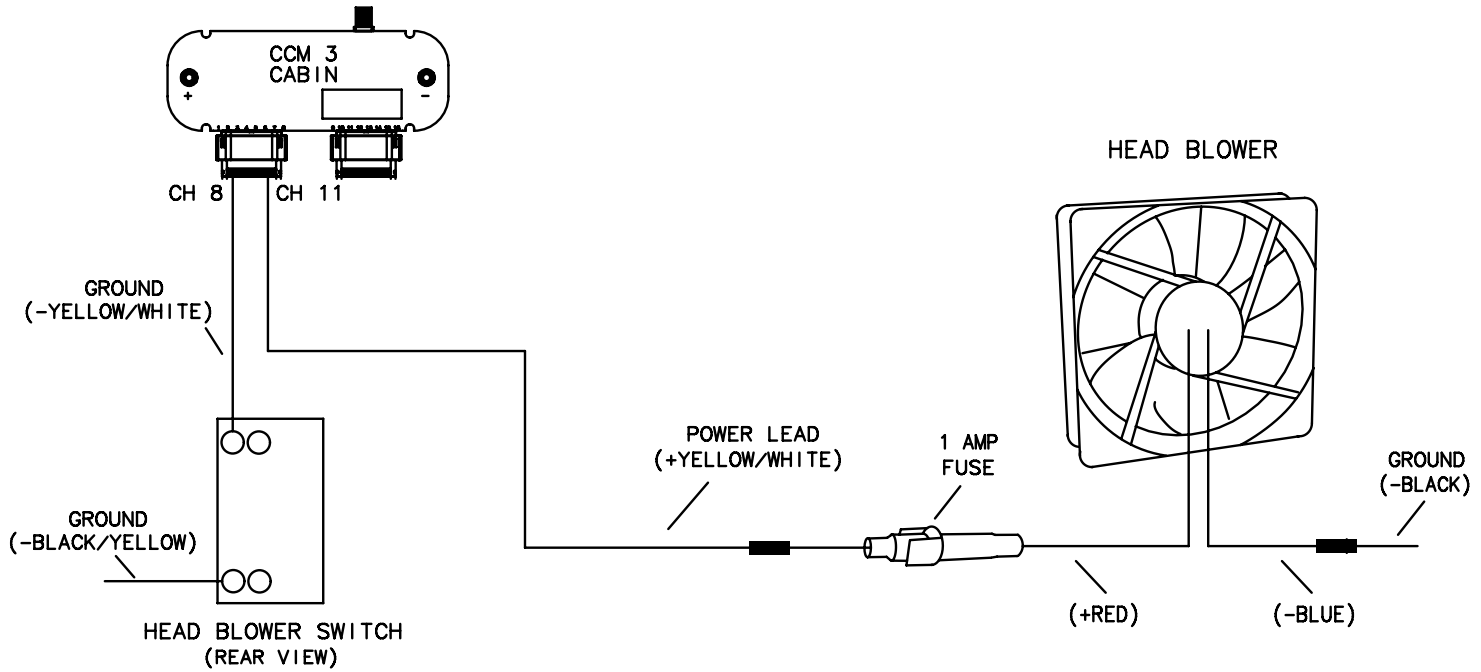

TITLE: HEAD BLOWER		THUNDERBIRD PRODUCTS
		P.O. BOX 1003
MOD.: 400 SSC	DR BY: KPP	DECATUR IN., 46733
NO.: 38	DATE:10-5-18	(260) 724-9111

LEGEND

C-BREAKER PANEL



PLUG INTERCONNECT



SIREN

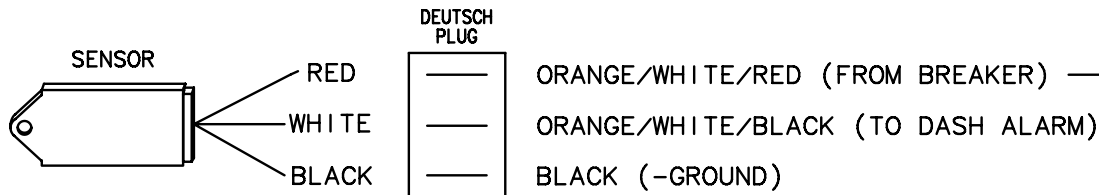

HIGH WATER ALARM BREAKER
(AFT BREAKER PANEL)
(REAR VIEW)

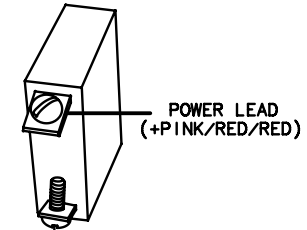

HIGH WATER ALARM SIREN
(LOCATED UNDER DASH)

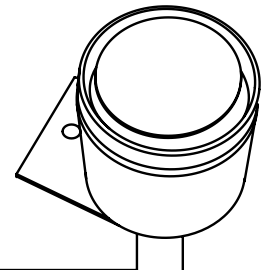

POWER LEAD (+ORANGE/BLACK/RED)
GROUND (-BLACK)

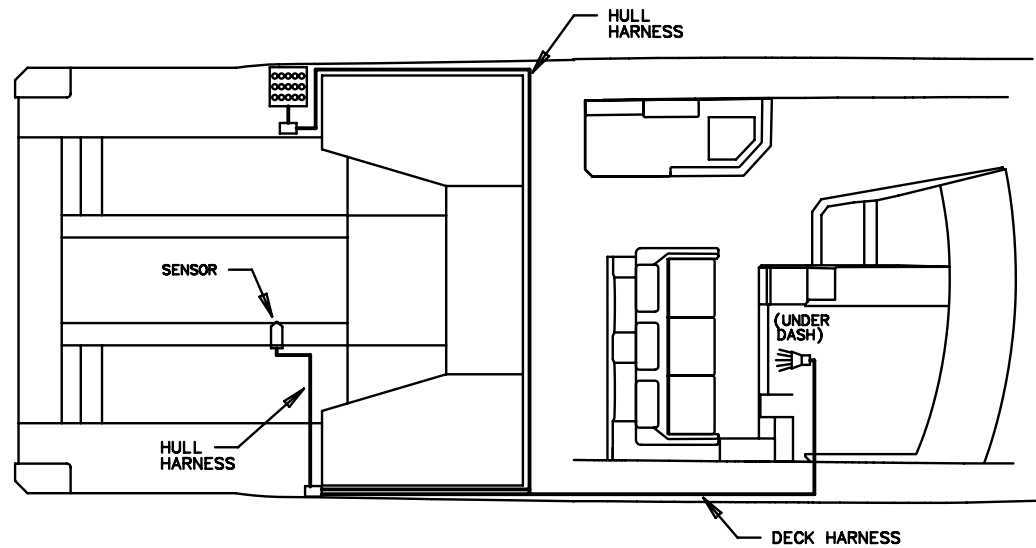

TITLE: HIGH WATER ALARM		THUNDERBIRD PRODUCTS
		P.O. BOX 1003
MOD.: 400 SSC	DR BY: KPP	DECATUR IN., 46733
NO.: 39	DATE: 10-5-18	(260) 724-9111

LEGEND

AIR HOSE 

PLUG INTERCONNECT 

C-BREAKER PANEL 

HORN BREAKER
(DASH BREAKER PANEL)
(REAR VIEW)

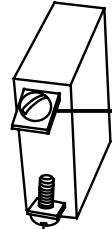

POWER LEAD
(+RED)

HORN SWITCH
(IGN. PANEL)
(REAR VIEW)

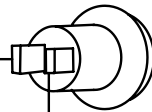

POWER LEAD
(+ORANGE/WHITE)

POWER LEAD
(+ORANGE/WHITE/WHITE)

BLACK
(-GROUND)

HORN
COMPRESSOR

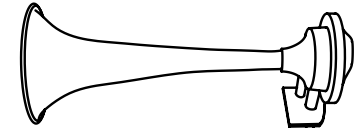
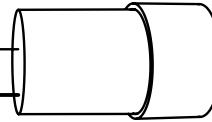

AIR HOSE

ONE WAY
AIR VALVE
(WITHIN 6"
OF COMPRESSOR)

HORN
COMPRESSOR
(UTILITY
LOCKER)

AIR HOSE RUNS UP COUPE
TOP LEG TO HORN

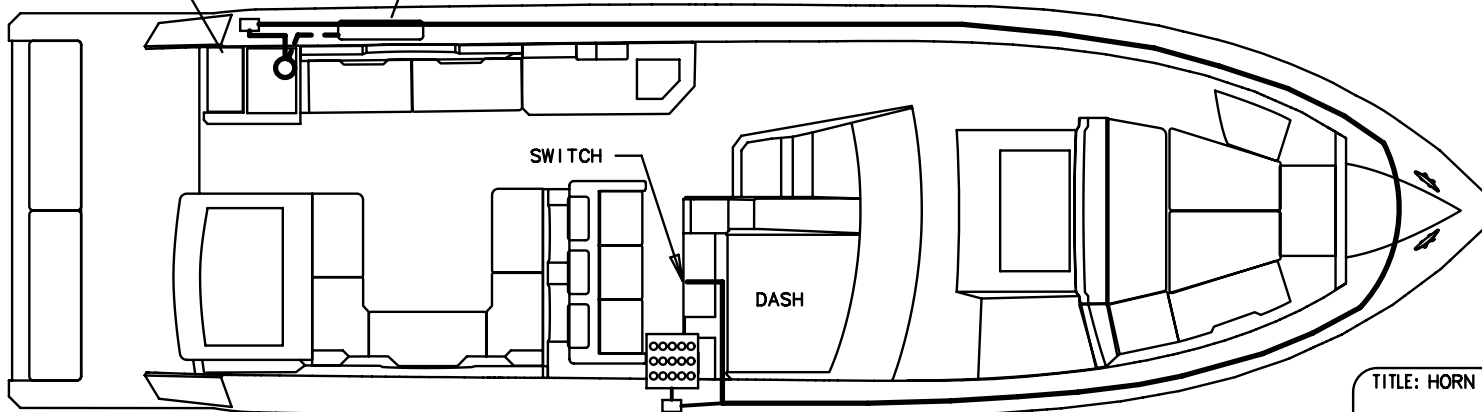

SWITCH

DASH

TITLE: HORN

THUNDERBIRD PRODUCTS

P.O. BOX 1003

MOD.: 400 SSC

DR BY: KPP

DECATUR IN., 46733

NO.: 40

DATE:10-5-18

(260) 724-9111

MAIN CABIN
LIGHT SWITCHES
(REAR VIEW)

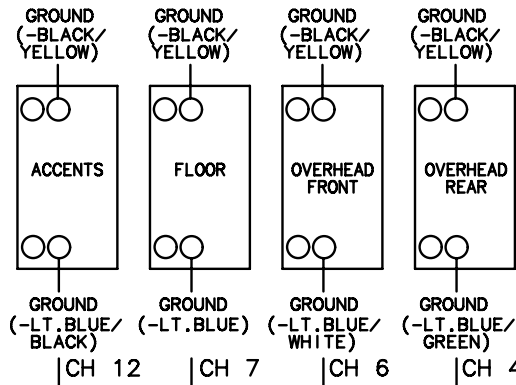

AFT CABIN
LIGHT SWITCHES
(REAR VIEW)

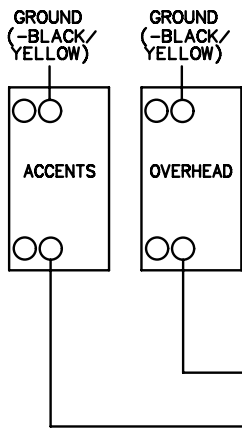

POWER LEAD
(+DK.BLUE/
BLACK/YELLOW)

AFT CABIN
ACCENT
CH 5

CH 15
GROUND
(-LT.BLUE/
WHITE/YELLOW)

GROUND
(-LT.BLUE/
BLACK/YELLOW)
CH 16

CCM 2
HELM

CH 17

CCM 1
HELM

CH 5

POWER LEAD
(+DK.BLUE/
WHITE/YELLOW)



AFT CABIN
OVERHEAD

POWER LEAD
(+DK.BLUE/
BLACK)

CH 17

ACCENT
LIGHTS

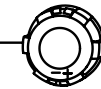

LIGHTED
SPEAKERS

POWER LEAD
(+LT.BLUE)

MAIN CABIN
FLOOR
CH 10

POWER LEAD
(+DK.BLUE/
WHITE)

POWER LEAD
(+DK.BLUE/
GREEN)

CH 4

MAIN CABIN
FRONT
OVERHEAD

CH 13

MAIN CABIN
REAR
OVERHEAD

TITLE: CABIN LIGHTS		THUNDERBIRD PRODUCTS
		P.O. BOX 1003
MOD.: 400 SSC	DR BY: KPP	DECATUR IN., 46733
NO.: 41	DATE:10-5-18	(260) 724-9111

PANEL LTS BREAKER
DASH BREAKER PANEL
(REAR VIEW)

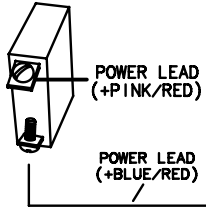

REMOTE LIGHTS
BOX

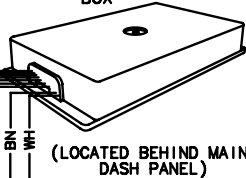

12 PIN DEUTSCH CONN.

REMOTE LTS BREAKER
AFT BREAKER PANEL
(REAR VIEW)

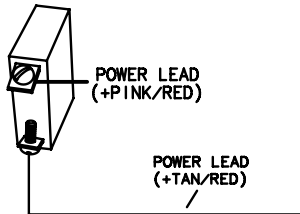

COURTESY LIGHTS
SWITCH
(DASH PANEL)
(REAR VIEW)

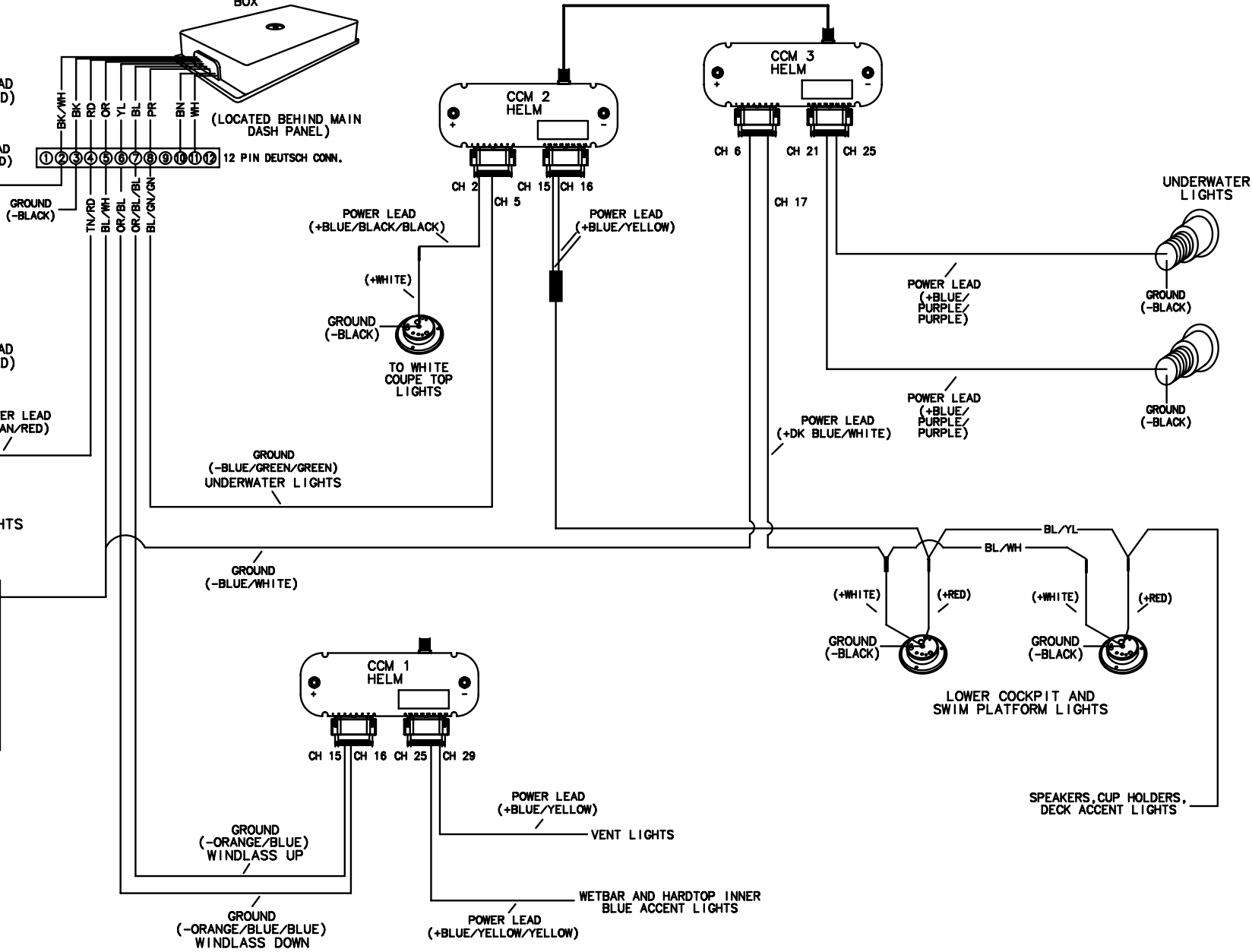
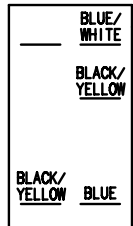

TITLE: COURTESY LIGHTS/ REMOTE BOX		THUNDERBIRD PRODUCTS
		P.O. BOX 1003
MOD.: 400 SSC	DR BY: KPP	DECATUR IN., 46733
NO.: 42	DATE: 10-5-18	(260) 724-9111

LEGEND

DOCKING LIGHT 

PLUG INTERCONNECT 

C-BREAKER PANEL 

LIGHTS BREAKER
(DASH BREAKER PANEL)
(REAR VIEW)

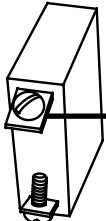

POWER LEAD
(+RED)

DOCKING LIGHTS SWITCH
(HELM PANEL)
(REAR VIEW)

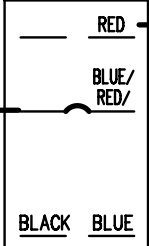

POWER LEAD
(+BLUE/RED)

POWER LEAD
(+RED)

DOCKING LIGHTS
(REAR VIEW)

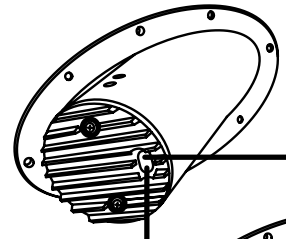

GROUND
(-BLACK)

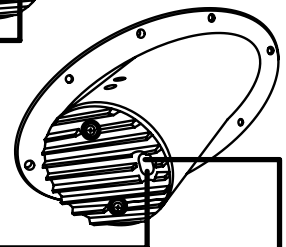

GROUND
(-BLACK)

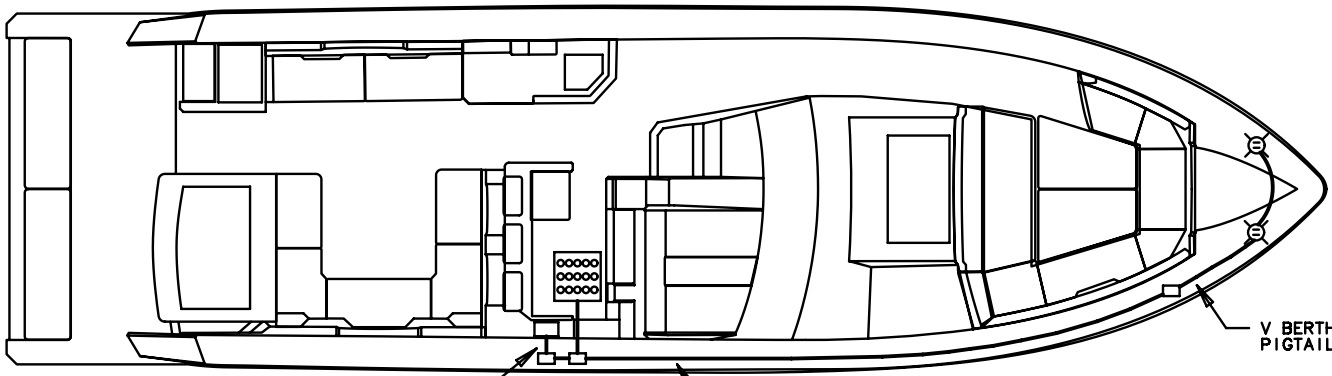

HELM SEAT
PIGTAIL

DECK
HARNESS

V BERTH
PIGTAIL

TITLE: DOCKING LIGHTS		THUNDERBIRD PRODUCTS
		P.O. BOX 1003
MOD.: 400 SSC	DR BY: KPP	DECATUR IN., 46733
NO.: 43	DATE:10-5-18	(260) 724-9111

LEGEND

PLUG INTERCONNECT 

LIGHT 

CCM 

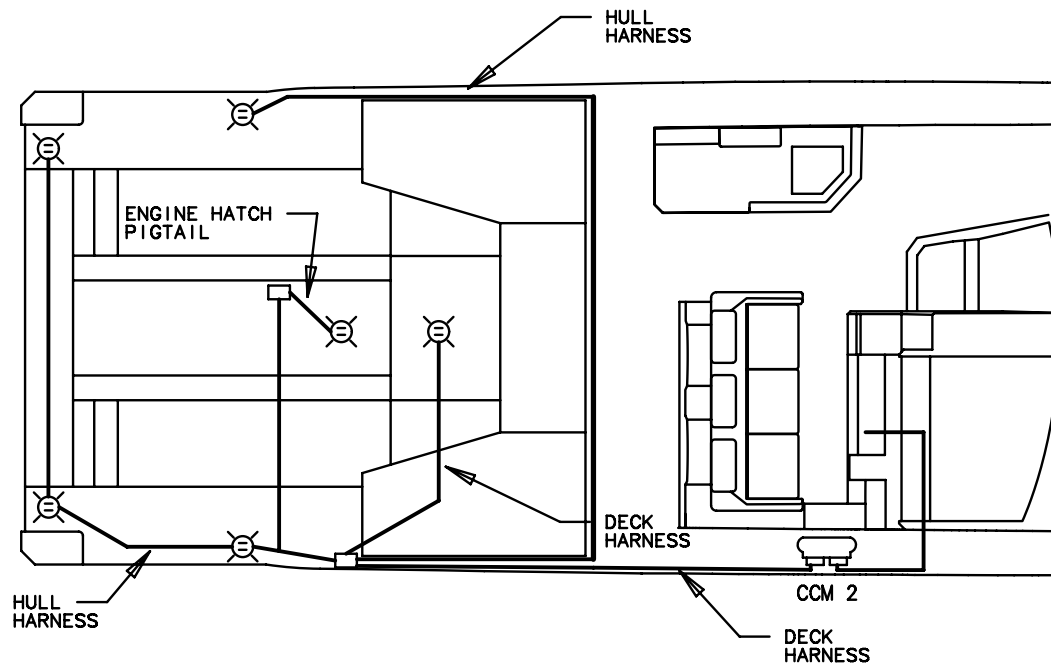
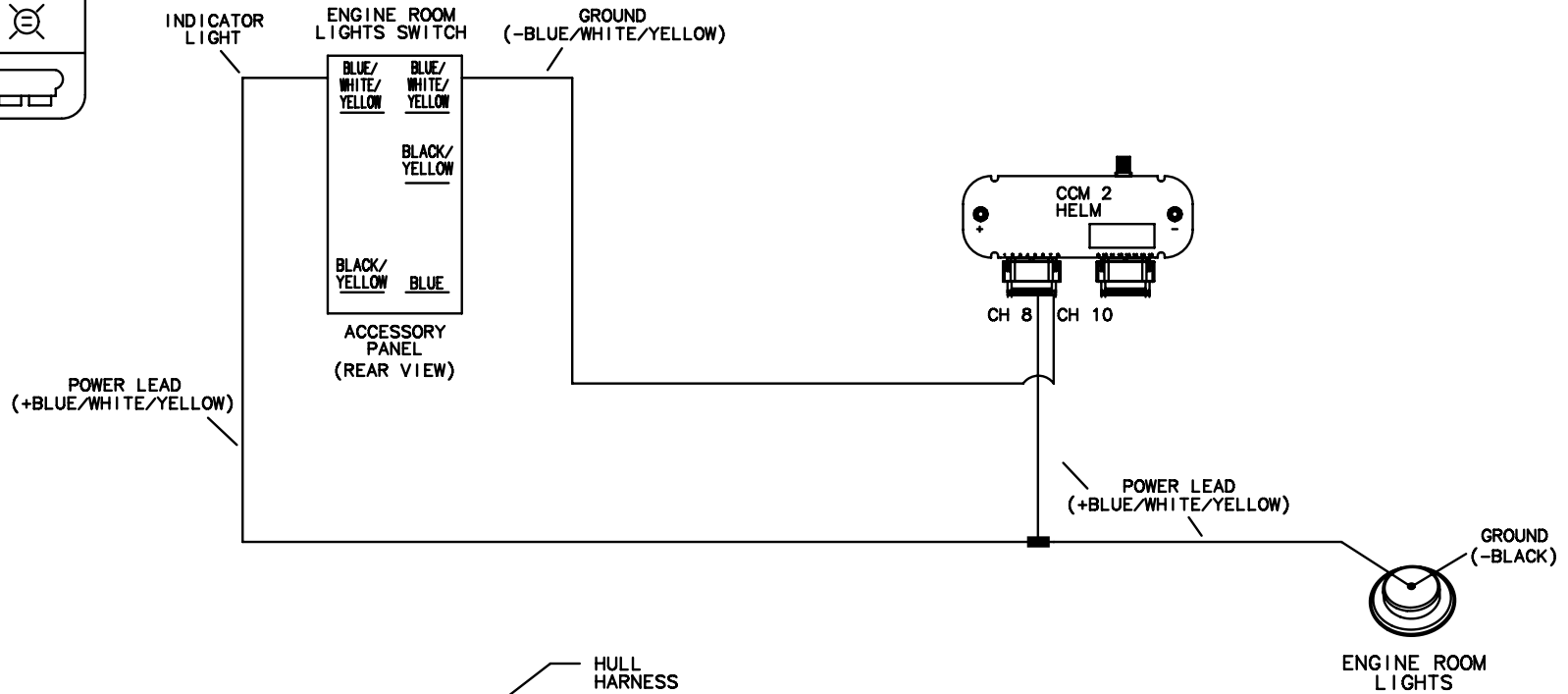

TITLE: EQUIPMENT ROOM, LIGHTS		THUNDERBIRD PRODUCTS
		P.O. BOX 1003
MOD.: 400 SSC	DR BY: KPP	DECATUR IN., 46733
NO.: 44	DATE:10-5-18	(260) 724-9111

LEGEND

LIGHT 

ACCENT LIGHT 

PLUG INTERCONNECT 

CCM 

HEAD UNIT SWITCHES (REAR VIEW)

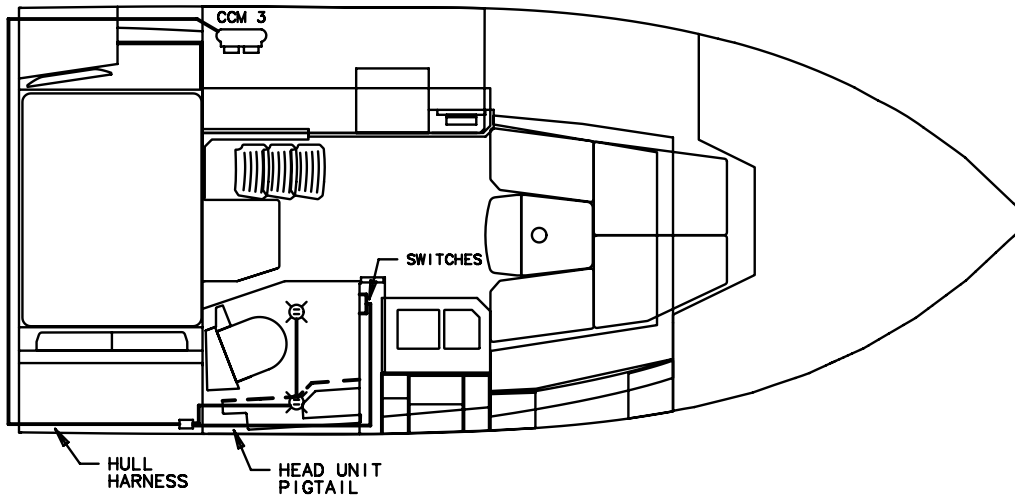
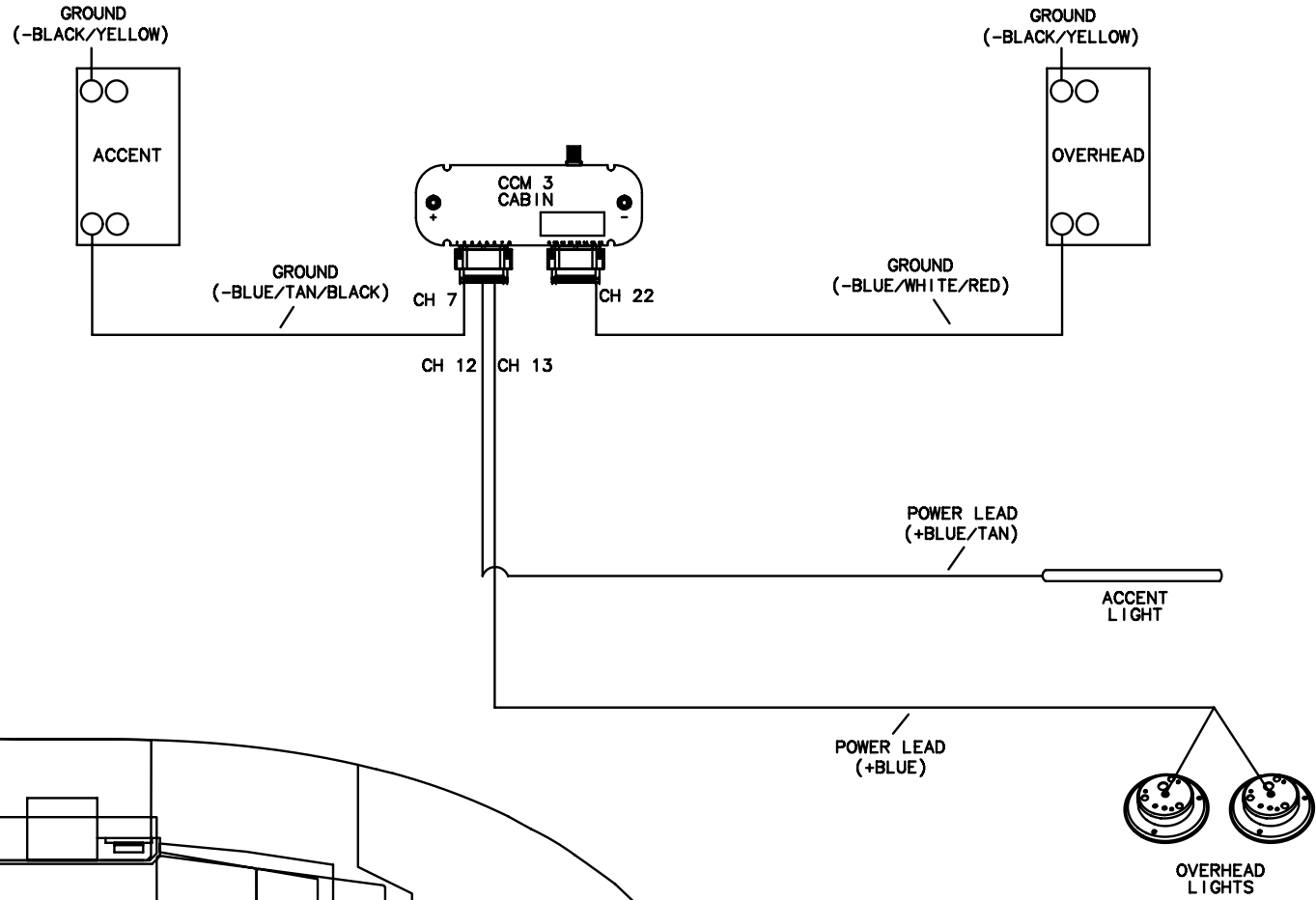

TITLE: HEAD LIGHTS		THUNDERBIRD PRODUCTS
		P.O. BOX 1003
MOD.: 400 SSC	DR BY: KPP	DECATUR IN., 46733
NO.: 45	DATE: 10-5-18	(260) 724-9111

LEGEND

PLUG INTERCONNECT 

C-BREAKER PANEL 

LIGHTS BREAKER
DASH BREAKER PANEL
(REAR VIEW)

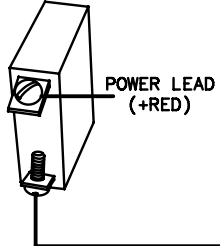

POWER LEAD
(+BLUE/RED)

NAV/ANCH LIGHTS SWITCH
(DASH PANEL)
(REAR VIEW)

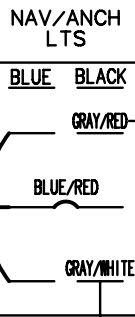

MAST/ANCHOR
LIGHT

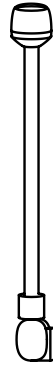

GROUND
(-BLACK)

POWER LEAD
(+GRAY/RED)

GROUND
(-BLACK)



PORT NAVIGATION LIGHT
(REAR VIEW)
(RED LIGHT)

GROUND
(-BLACK)



STBD NAVIGATION LIGHT
(REAR VIEW)
(GREEN LIGHT)

POWER LEAD
(+GRAY/WHITE)

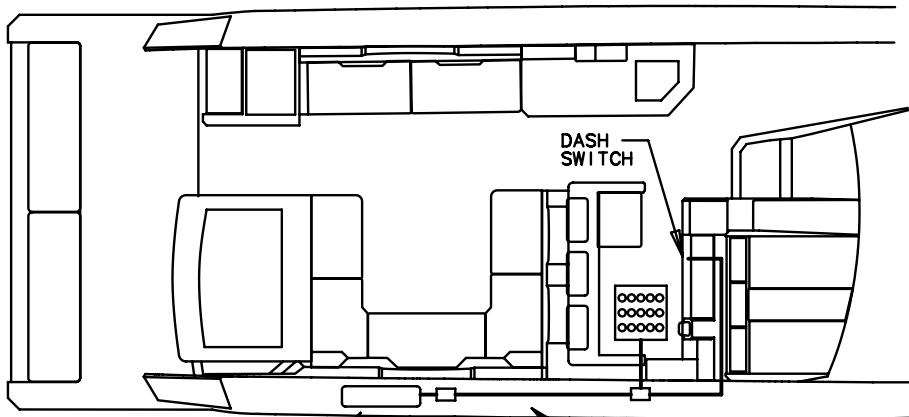

TO COUPE TOP

DECK
HARNESS

TITLE: NAVIGATION/ANCHOR LIGHTS		THUNDERBIRD PRODUCTS
		P.O. BOX 1003
MOD.: 400 SSC	DR BY: KPP	DECATUR IN., 46733
NO.: 46	DATE:10-5-18	(260) 724-9111

SPOTLIGHT BREAKER
(DASH BREAKER PANEL)
(REAR VIEW)

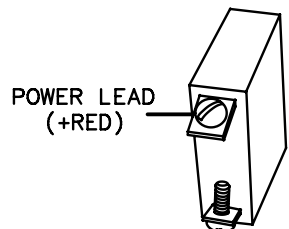

POWER LEAD
(+GRAY/ORANGE)

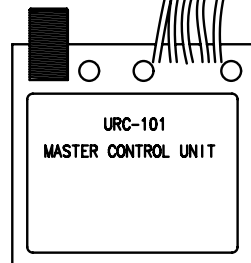
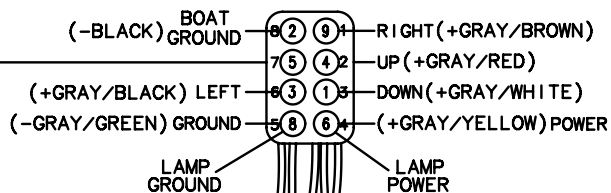

- 1 WHITE
- 2 BLUE
- 3 BLACK
- 4 RED
- 5 ORANGE
- 6 YELLOW
- 7 NOT USED
- 8 GREEN
- 9 BROWN

(HARDTOP)

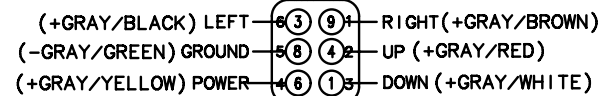
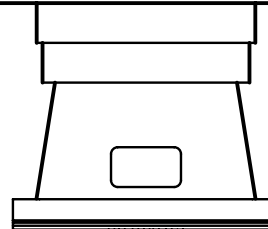
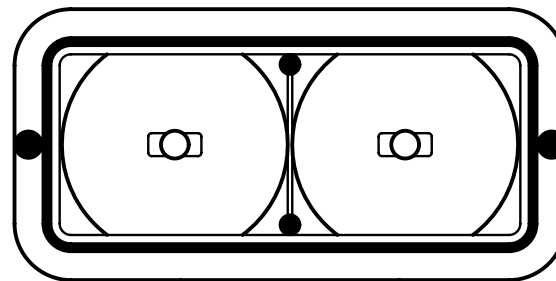

- 1 WHITE
- 2 NOT USED
- 3 BLACK
- 4 RED
- 5 NOT USED
- 6 YELLOW
- 7 NOT USED
- 8 GREEN
- 9 BROWN

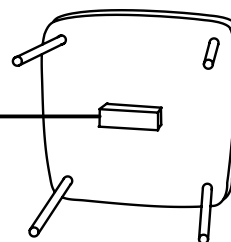

CONTROL PAD
(REAR VIEW)

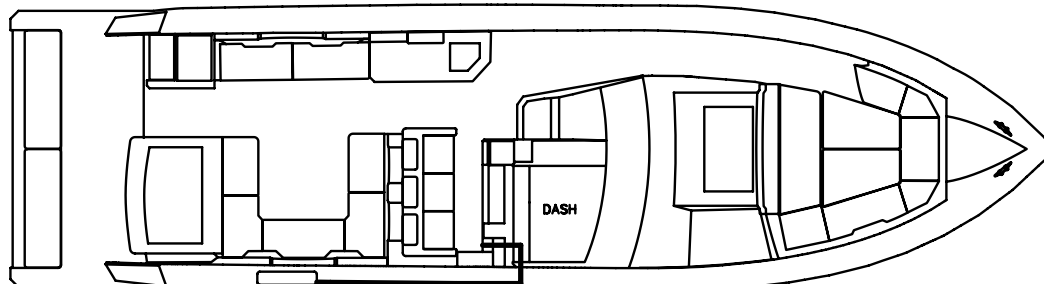

TITLE: SPOTLIGHT		THUNDERBIRD PRODUCTS
		P.O. BOX 1003
MOD.: 400 SSC	DR BY: KPP	DECATUR IN., 46733
NO.: 47	DATE:10-5-18	(260) 724-9111

LEGEND

PLUG INTERCONNECT 

CCM 

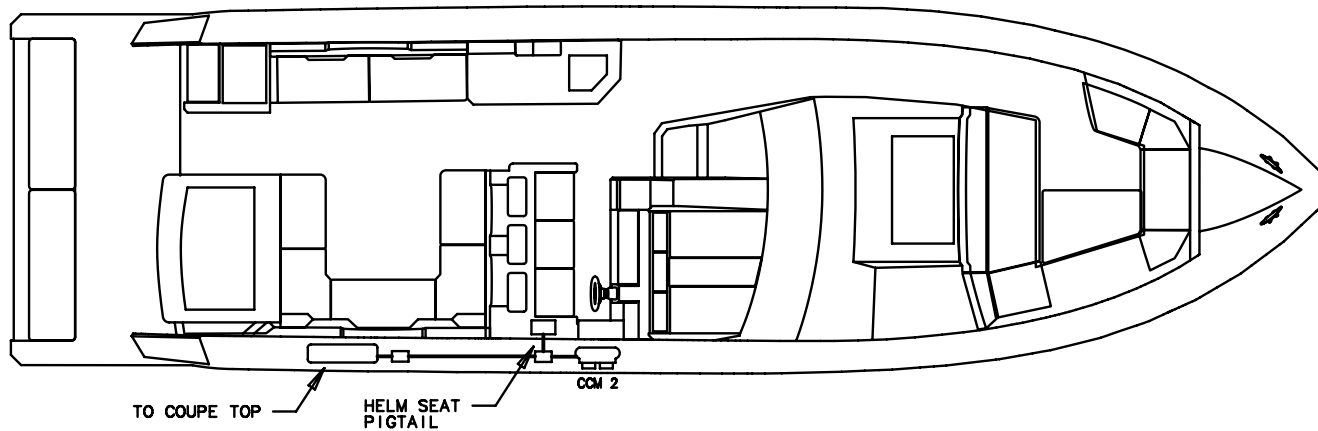
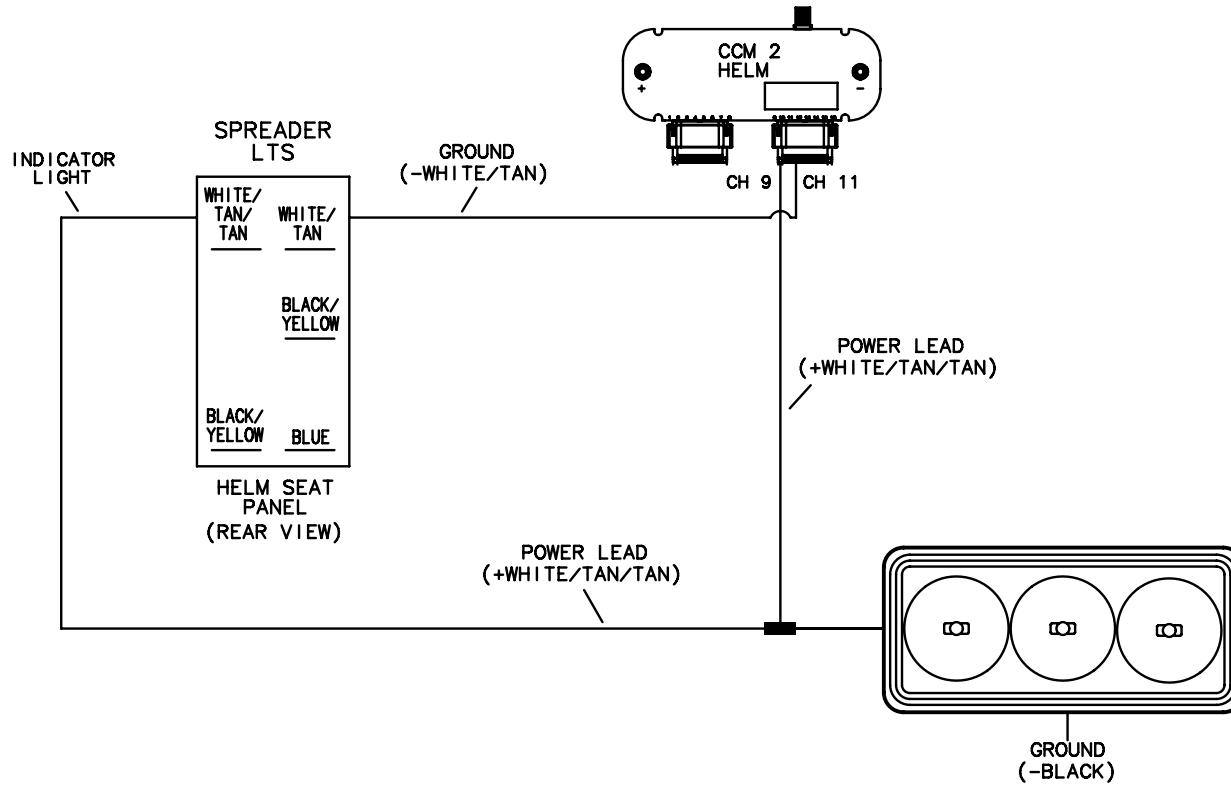

TITLE: SPREADER LIGHTS		THUNDERBIRD PRODUCTS
		P.O. BOX 1003
MOD.: 400 SSC	DR BY: KPP	DECATUR IN., 46733
NO.: 48	DATE: 10-5-18	(260) 724-9111

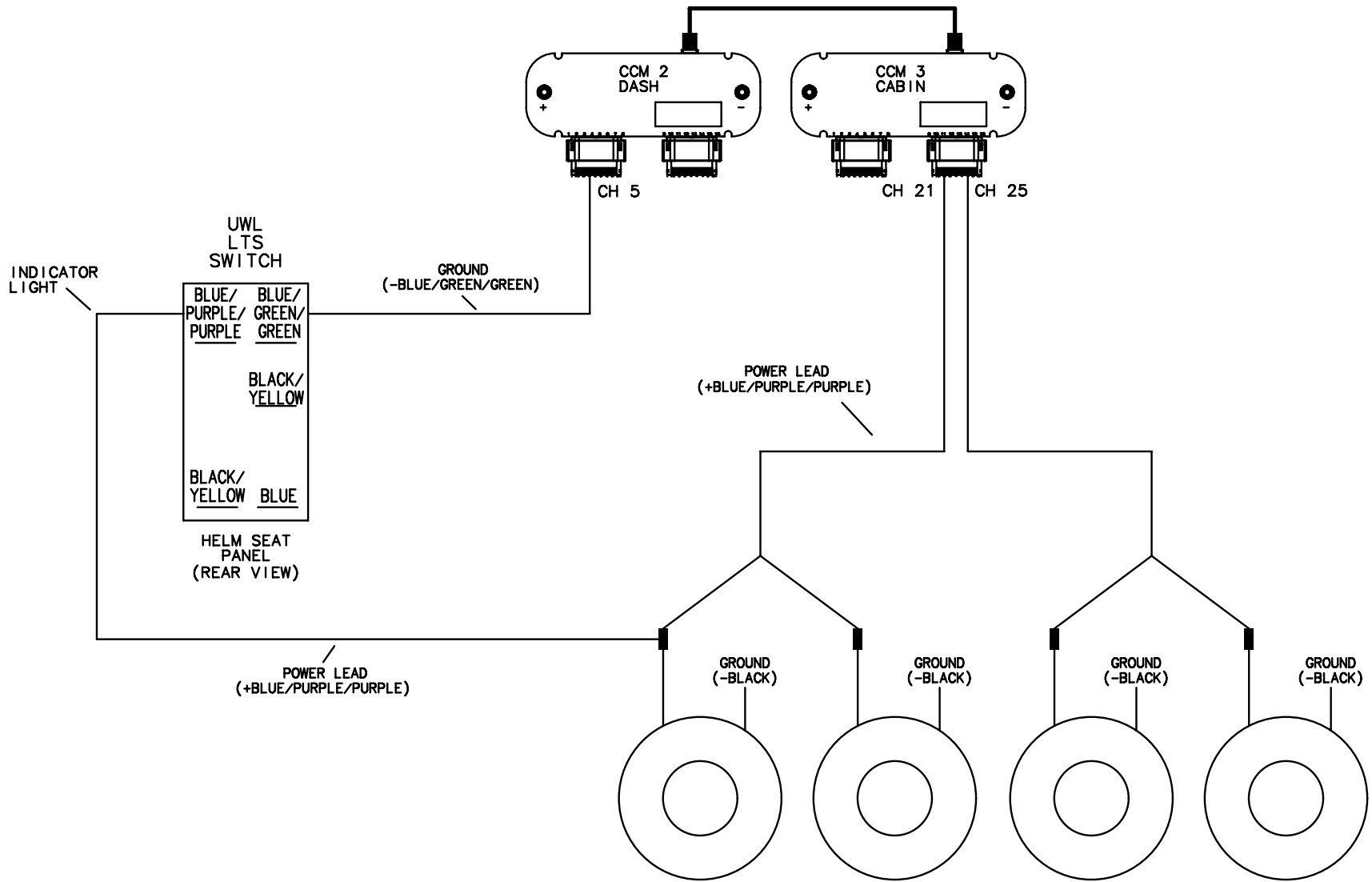

TITLE: UNDERWATER LIGHTS		THUNDERBIRD PRODUCTS
		P.O. BOX 1003
MOD.: 400 SSC	DR BY: KPP	DECATUR IN., 46733
NO.: 49	DATE: 10-5-18	(260) 724-9111

WASTE SYSTEM BREAKER
CABIN DC PANEL
(REAR VIEW)

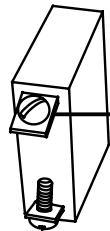

POWER LEAD
(+RED)

MACERATOR
CONTROL

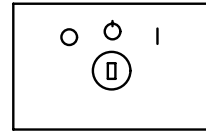

(HEAD UNIT)

DEUTSCH
CONNECTOR

- GREEN — BLACK/WHITE/YELLOW (TO "EMPTY" FLOAT)
- BROWN — GREEN/ORANGE (TO MACERATOR)
- RED — GREEN/RED (POWER IN)
- BLACK — BLACK (GROUND)

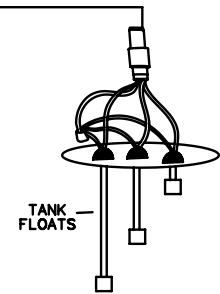

TANK
FLOATS

POWER LEAD
(+GREEN/RED)

GROUND
(-BLACK)

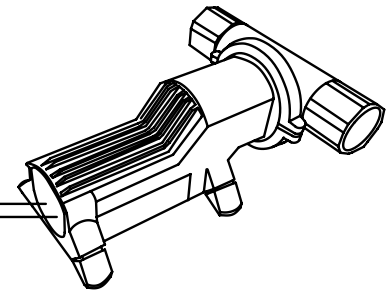

MACERATOR

TITLE: MACERATOR		THUNDERBIRD PRODUCTS
		P.O. BOX 1003
MOD.: 400 SSC	DR BY: KPP	DECATUR IN., 46733
NO.: 50	DATE: 10-5-18	(260) 724-9111

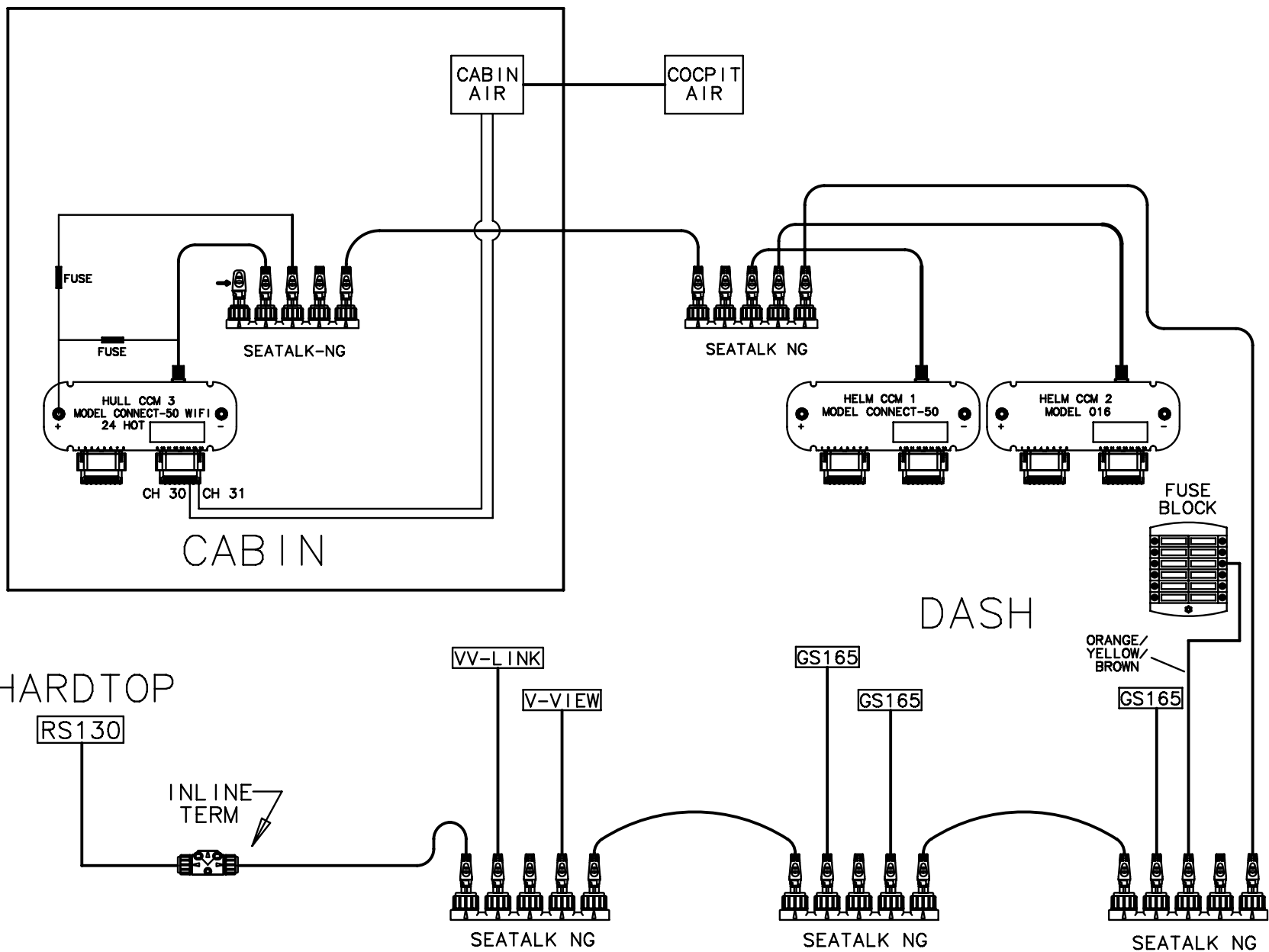

TITLE: NEMA 2000		THUNDERBIRD PRODUCTS
		P.O. BOX 1003
MOD.: 400 SSC	DR BY: KPP	DECATUR IN., 46733
NO.: 51	DATE: 10-5-18	(260) 724-9111

SHOWER SUMP BREAKER
AFT BREAKER PANEL
(REAR VIEW)



POWER LEAD
(+PINK/RED)

POWER LEAD
(+RED/GRAY)

POWER LEAD
(+RED/GRAY/WHITE)

POWER LEAD
(+BROWN/WHITE)

POWER LEAD
(+BROWN)

POWER LEAD
(+RED/GRAY/GRAY)

FLOAT
SWITCH

POWER LEAD
(+RED/GRAY/GRAY)

GROUND
(-BLACK)

SUMP BOX

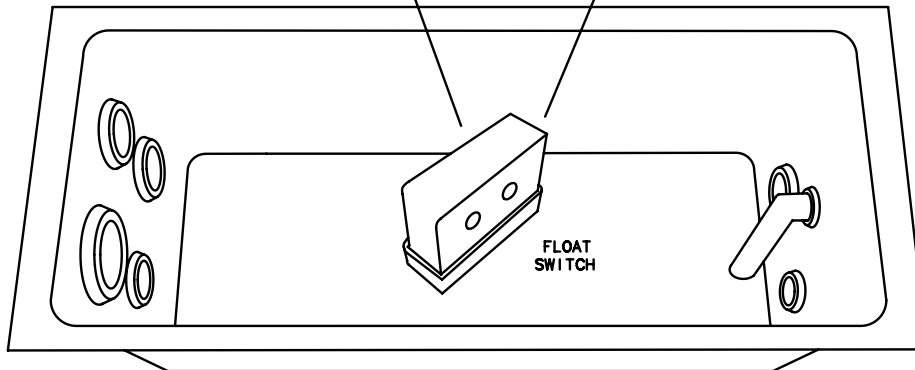

FLOAT
SWITCH

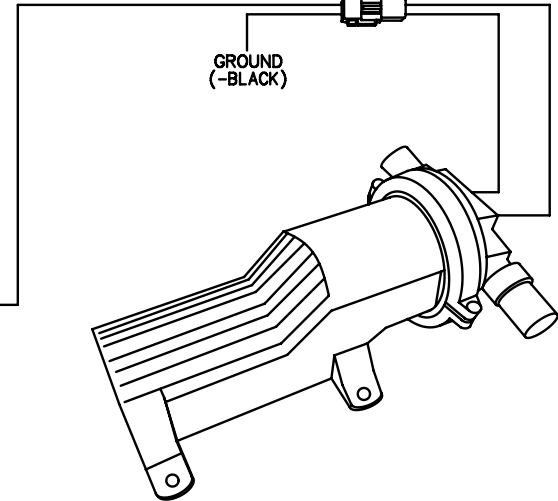

TITLE: SHOWER SUMP (ELECTRICAL)		THUNDERBIRD PRODUCTS
		P.O. BOX 1003
MOD.: 400 SSC	DR BY: KPP	DECATUR IN., 46733
NO.: 52	DATE: 10-5-18	(260) 724-9111

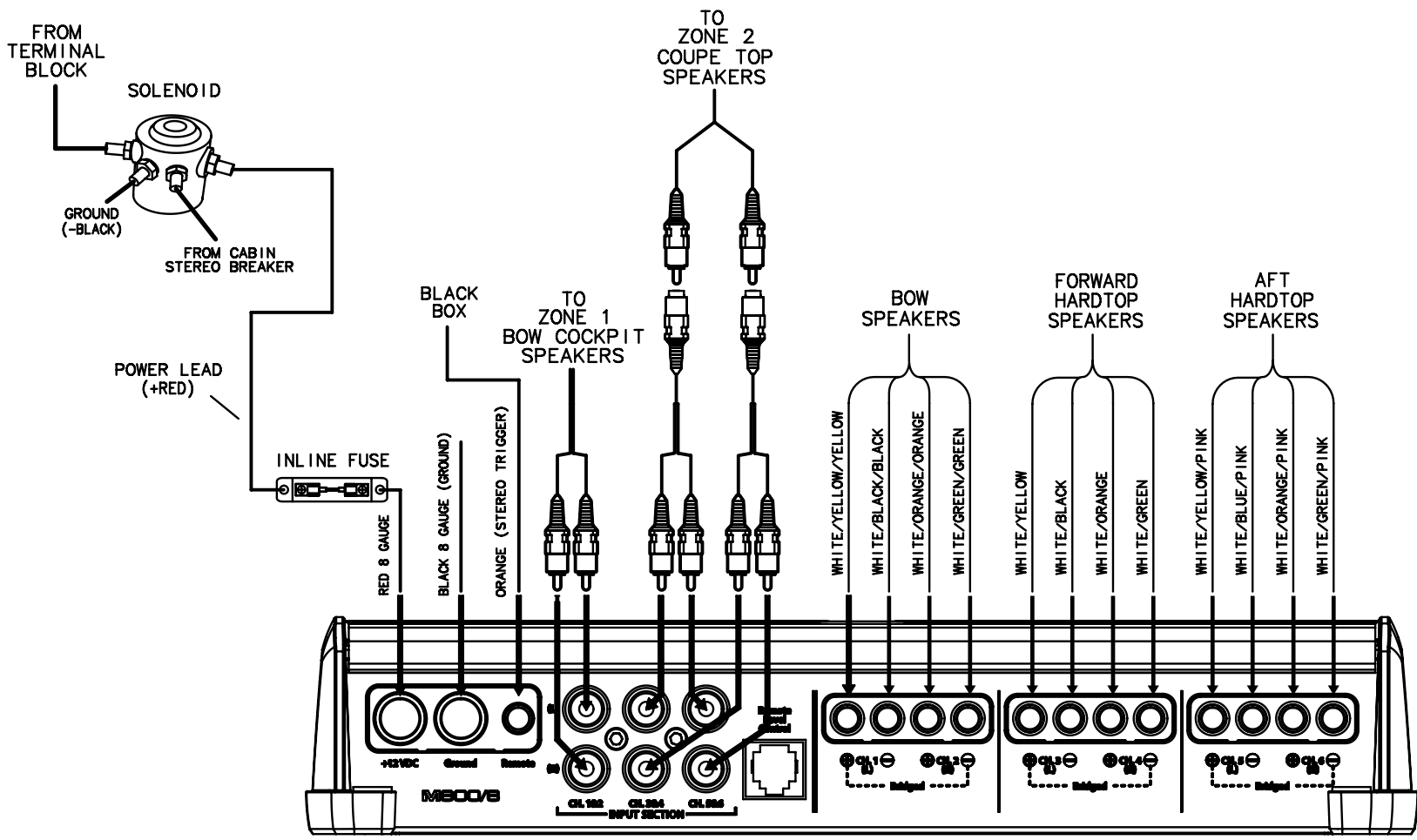

(LOCATED BEHIND AFT CABIN HEAD REST)

TITLE: STEREO AMP		THUNDERBIRD PRODUCTS
		P.O. BOX 1003
MOD.: 400 SSC	DR BY: KPP	DECATUR IN., 46733
NO.: 53	DATE: 10-5-18	(260) 724-9111

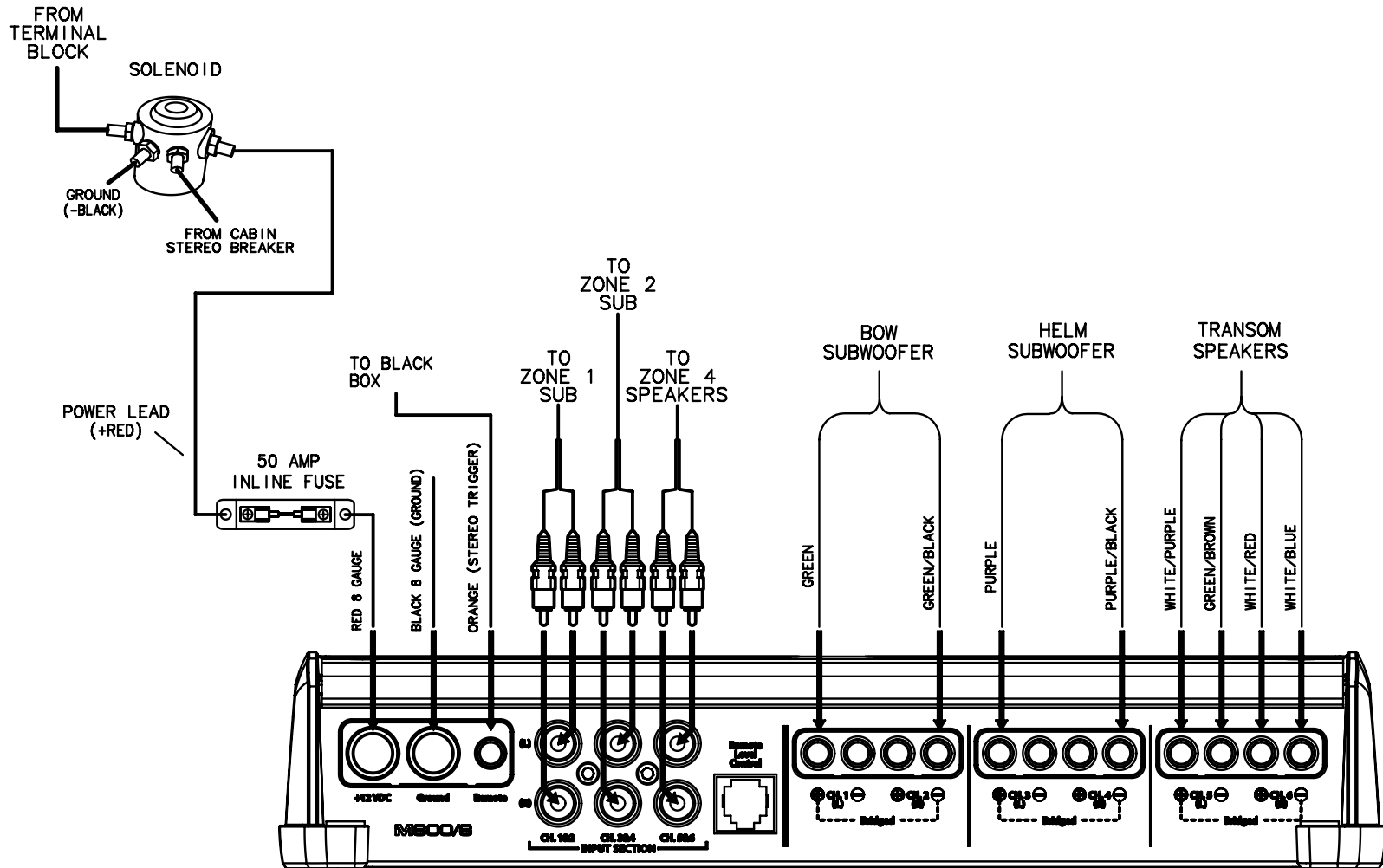

(LOCATED BEHIND AFT CABIN HEAD REST)

TITLE: STEREO AMP 2		THUNDERBIRD PRODUCTS
		P.O. BOX 1003
MOD.: 400 SSC	DR BY: KPP	DECATUR IN., 46733
NO.: 54	DATE: 10-5-18	(260) 724-9111

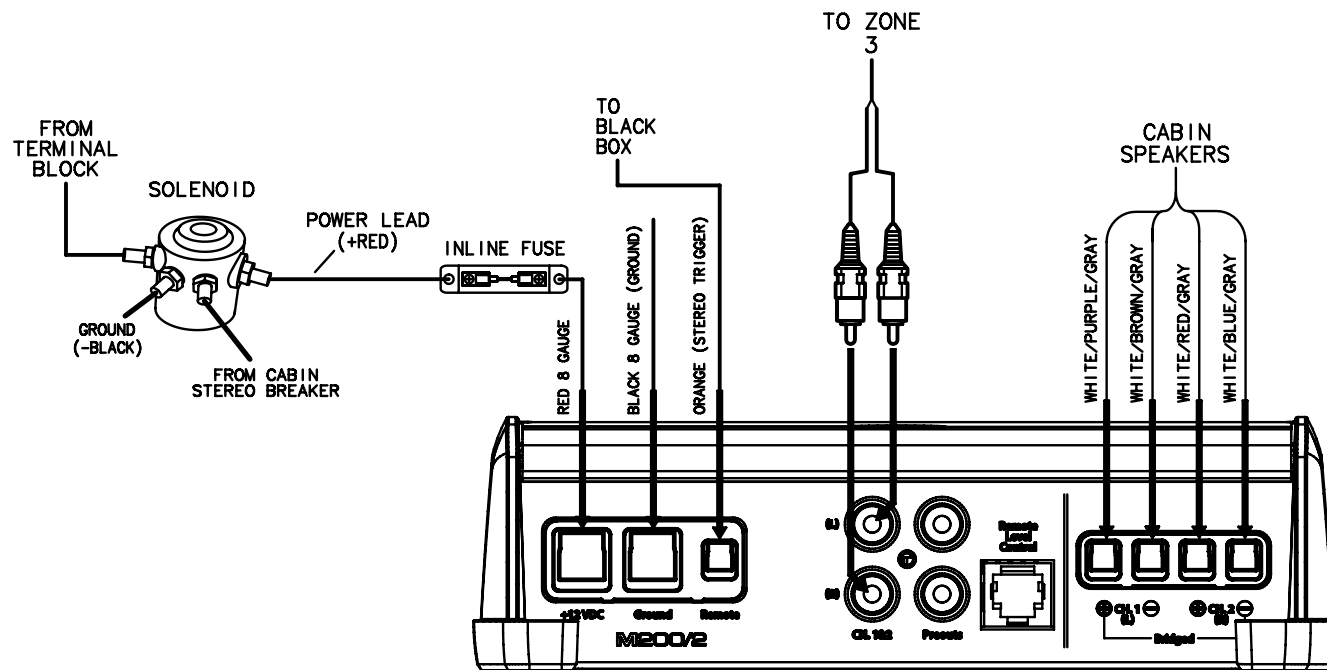

(LOCATED BEHIND AFT CABIN HEAD REST)

TITLE: STEREO AMP 3		THUNDERBIRD PRODUCTS
		P.O. BOX 1003
MOD.: 400 SSC	DR BY: KPP	DECATUR IN., 46733
NO.: 55	DATE:10-5-18	(260) 724-9111

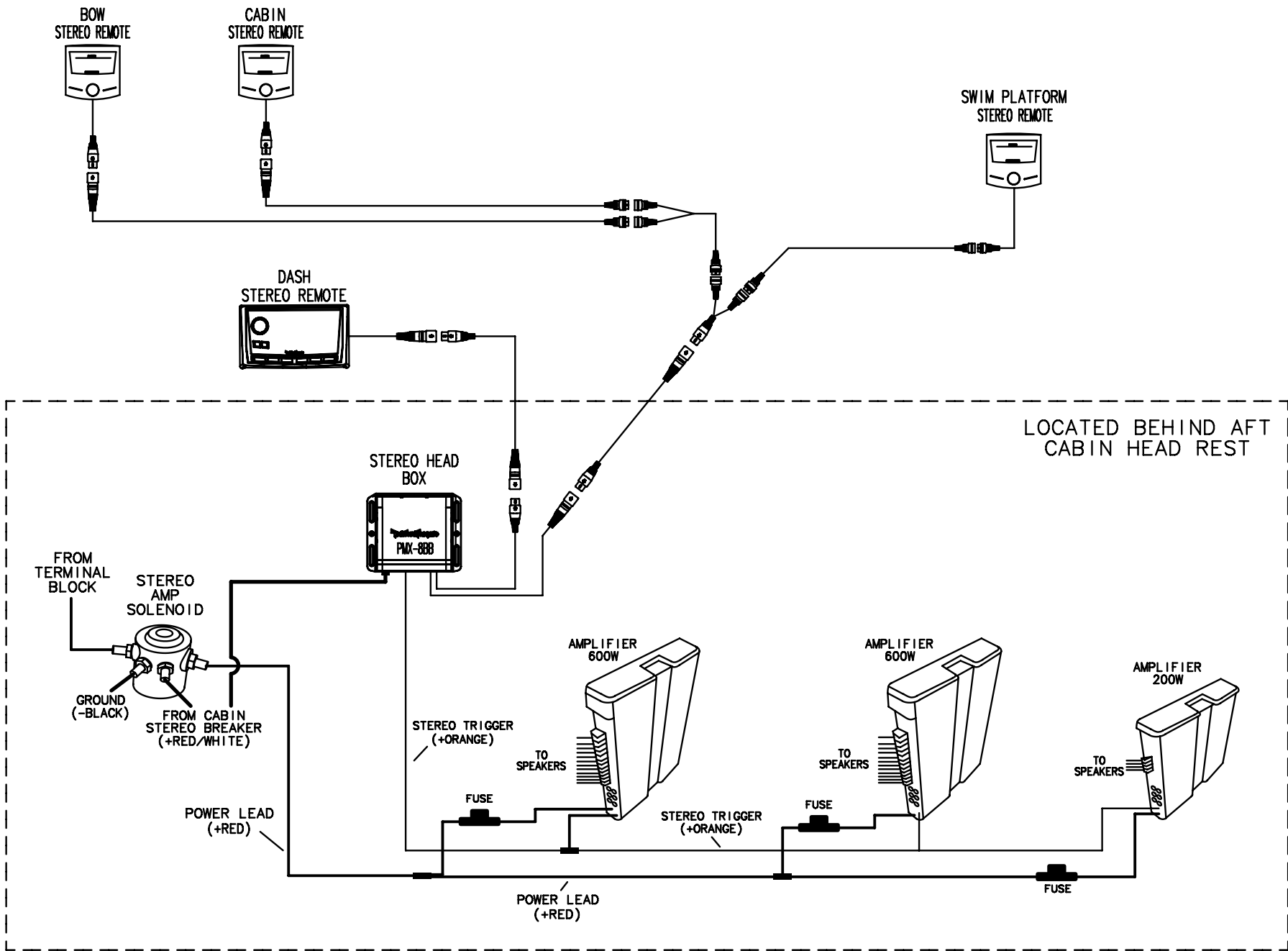

TITLE: STEREO SYSTEM		THUNDERBIRD PRODUCTS
		P.O. BOX 1003
MOD.: 400 SSC	DR BY: KPP	DECATUR IN., 46733
NO.: 56	DATE: 10-5-18	(260) 724-9111

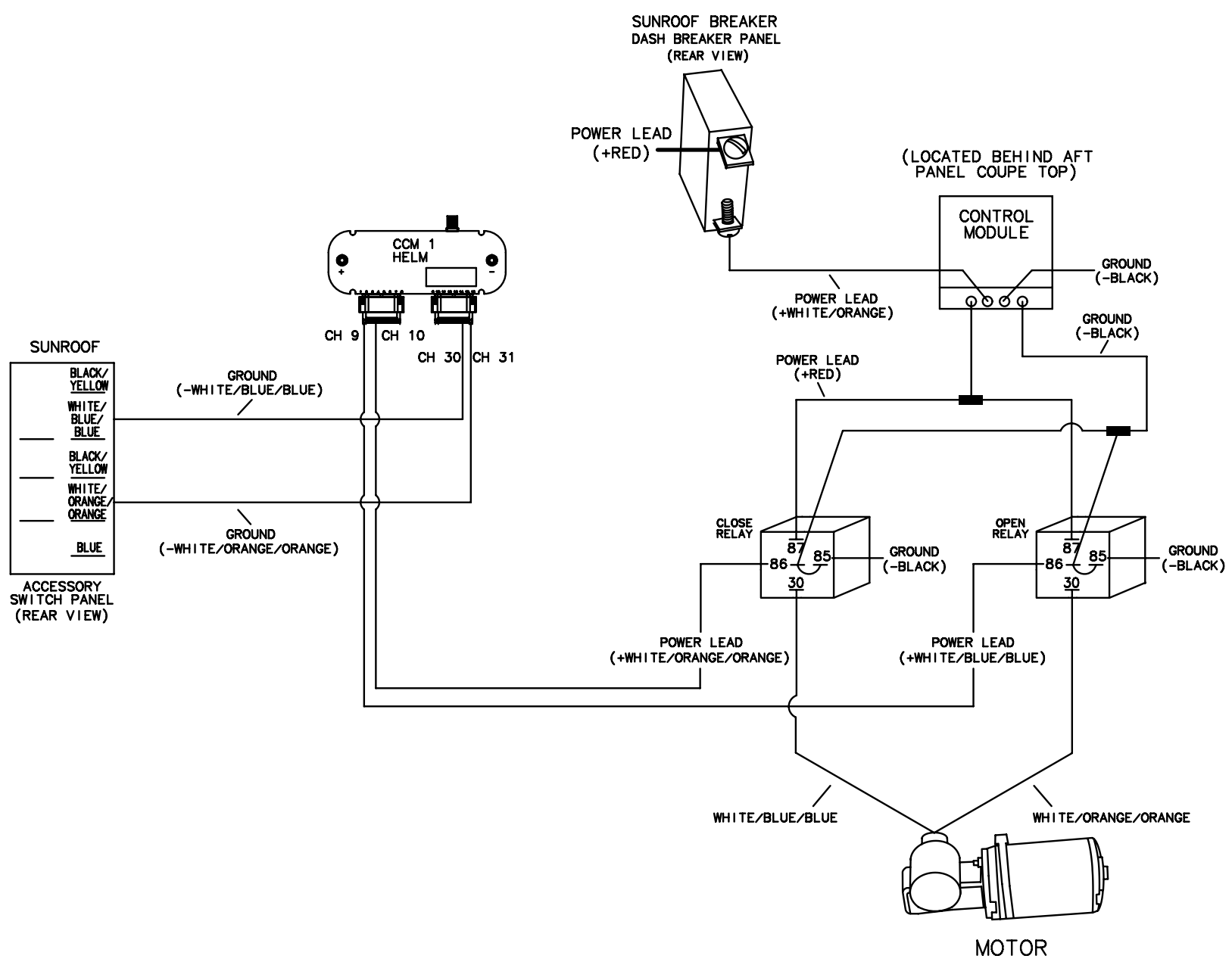

TITLE: SUN ROOF		THUNDERBIRD PRODUCTS
		P.O. BOX 1003
MOD.: 400 SSC	DR BY: KPP	DECATUR IN., 46733
NO.: 57	DATE: 10-5-18	(260) 724-9111

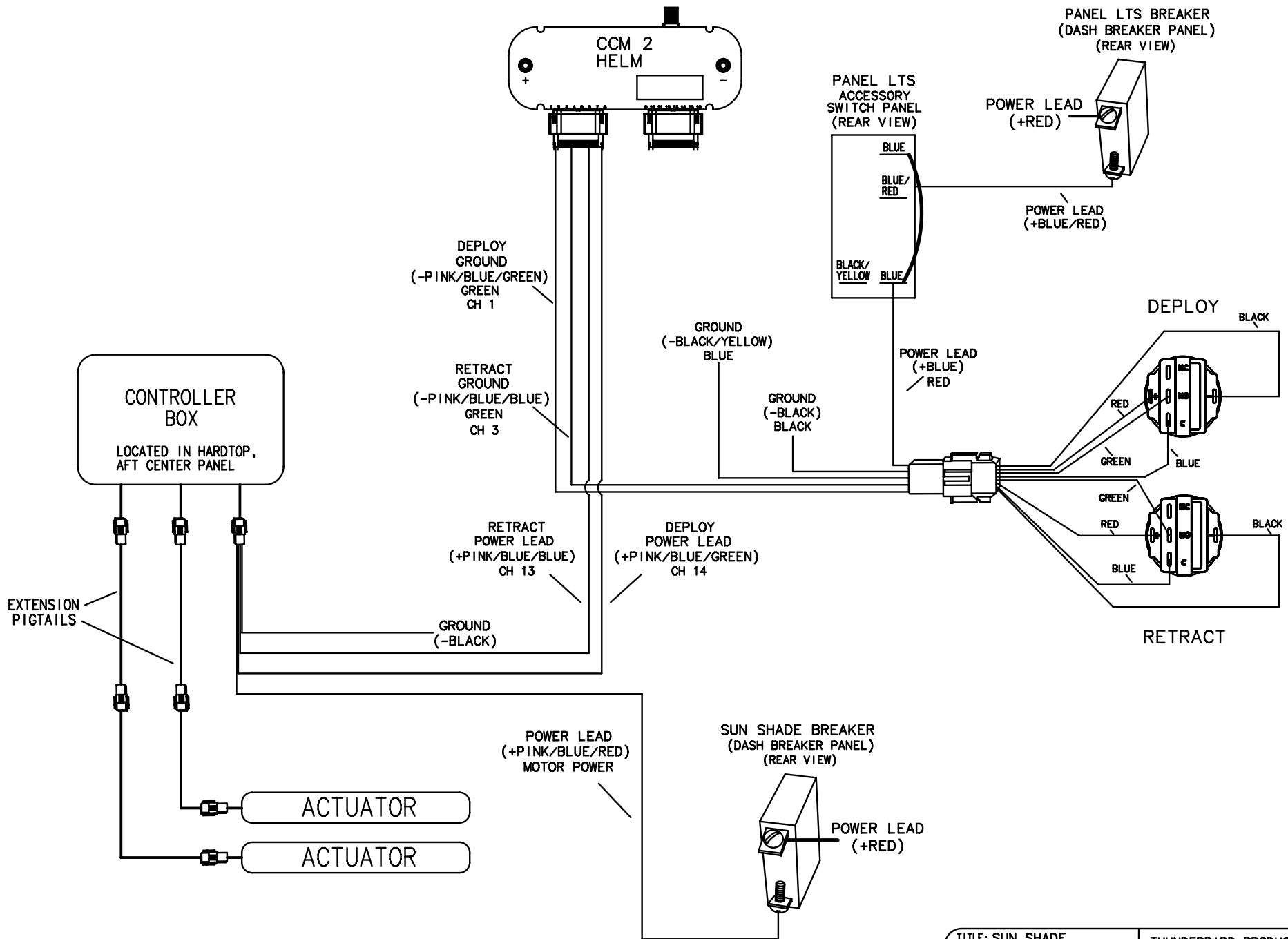

TITLE: SUN SHADE		THUNDERBIRD PRODUCTS
		P.O. BOX 1003
MOD.: 400 SSC	DR BY: KPP	DECATUR IN., 46733
NO.: 58	DATE: 10-5-18	(260) 724-9111

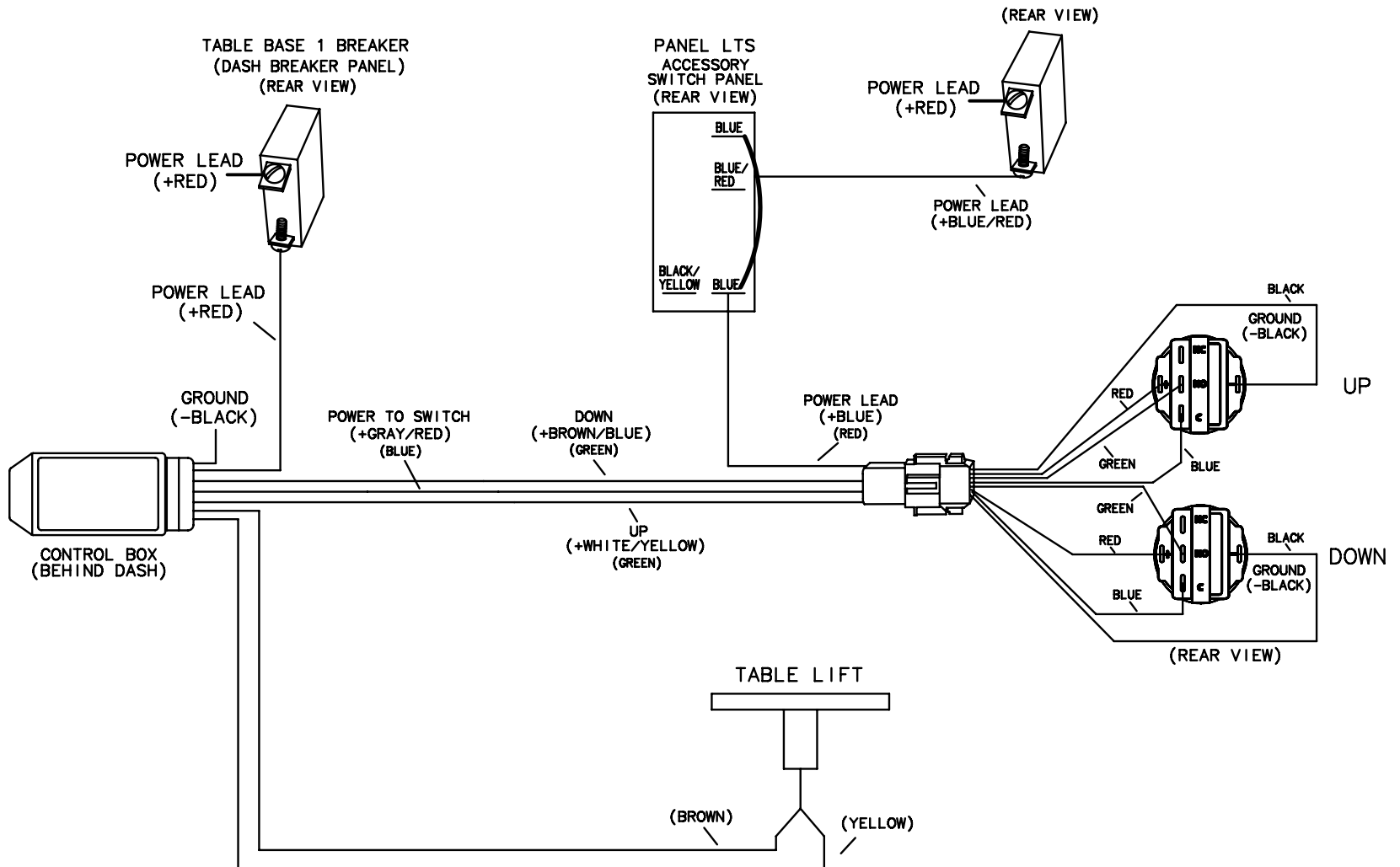

TITLE: TABLE LIFT		THUNDERBIRD PRODUCTS
		P.O. BOX 1003
MOD.: 400 SSC	DR BY: KPP	DECATUR IN., 46733
NO.: 59	DATE: 10-5-18	(260) 724-9111

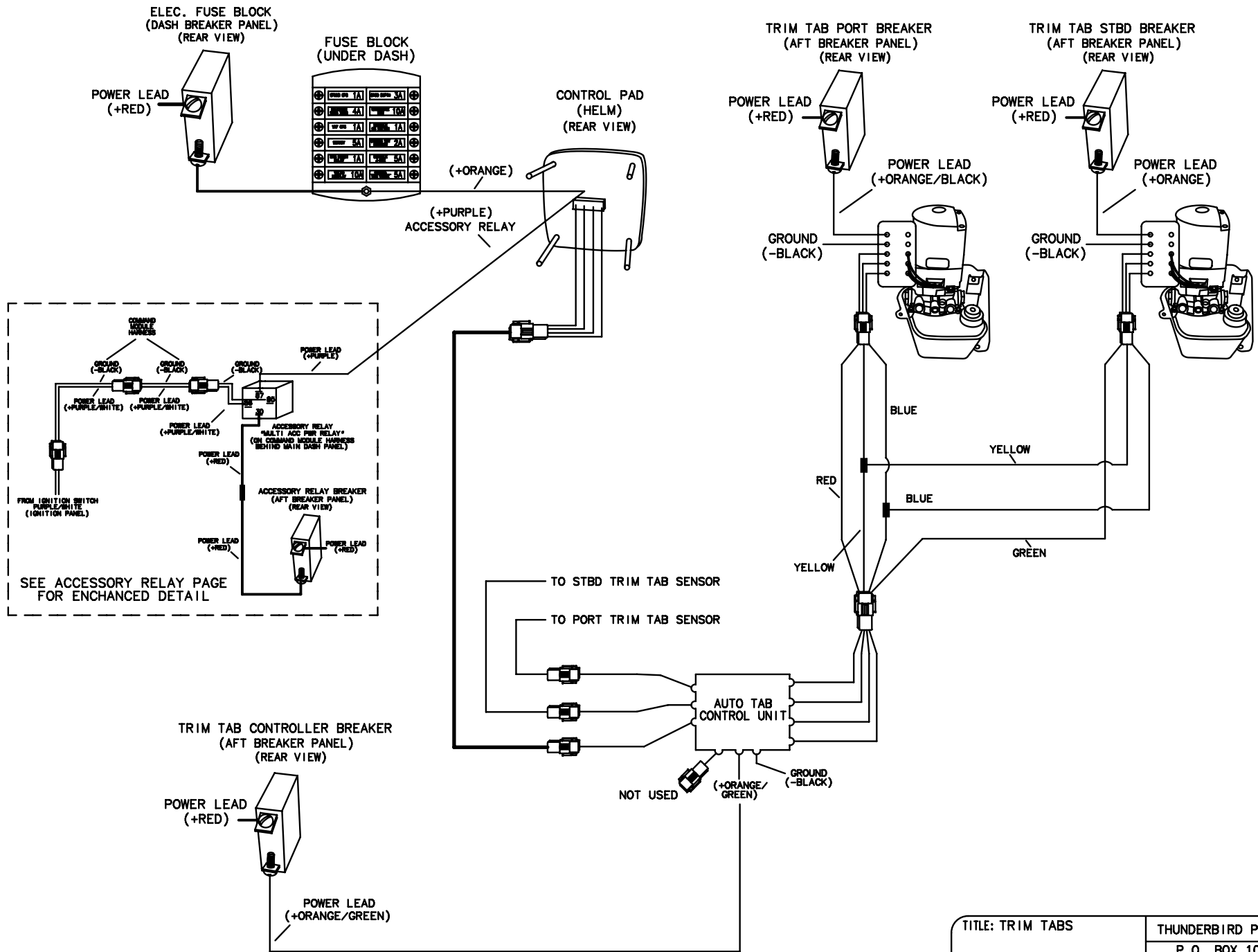

TITLE: TRIM TABS		THUNDERBIRD PRODUCTS
		P.O. BOX 1003
MOD.: 400 SSC	DR BY: KPP	DECATUR IN., 46733
NO.: 60	DATE: 10-5-18	(260) 724-9111

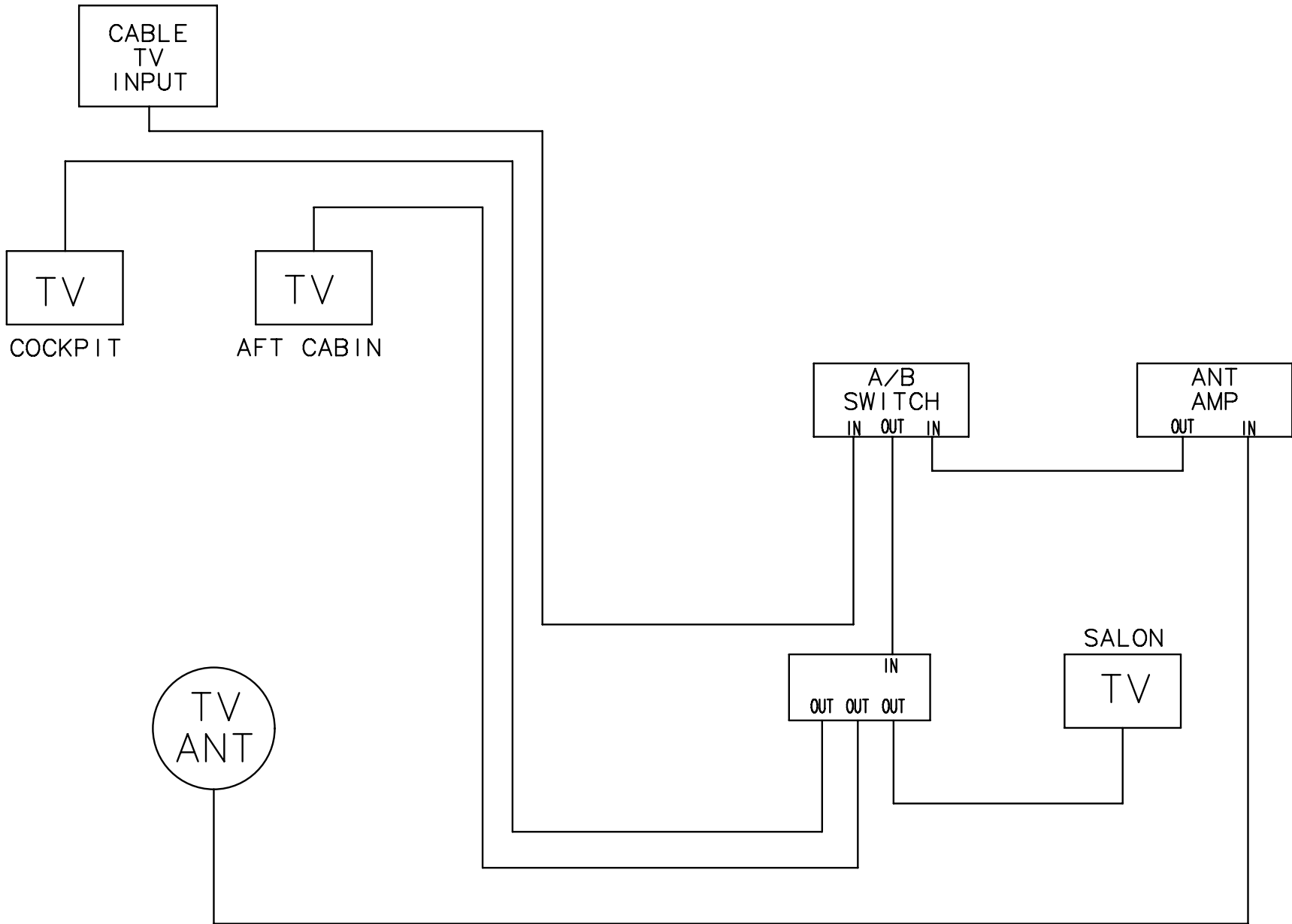

TITLE: TV INPUT		THUNDERBIRD PRODUCTS
		P.O. BOX 1003
MOD.: 400 SSC	DR BY: KPP	DECATUR IN., 46733
NO.: 61	DATE: 10-5-18	(260) 724-9111

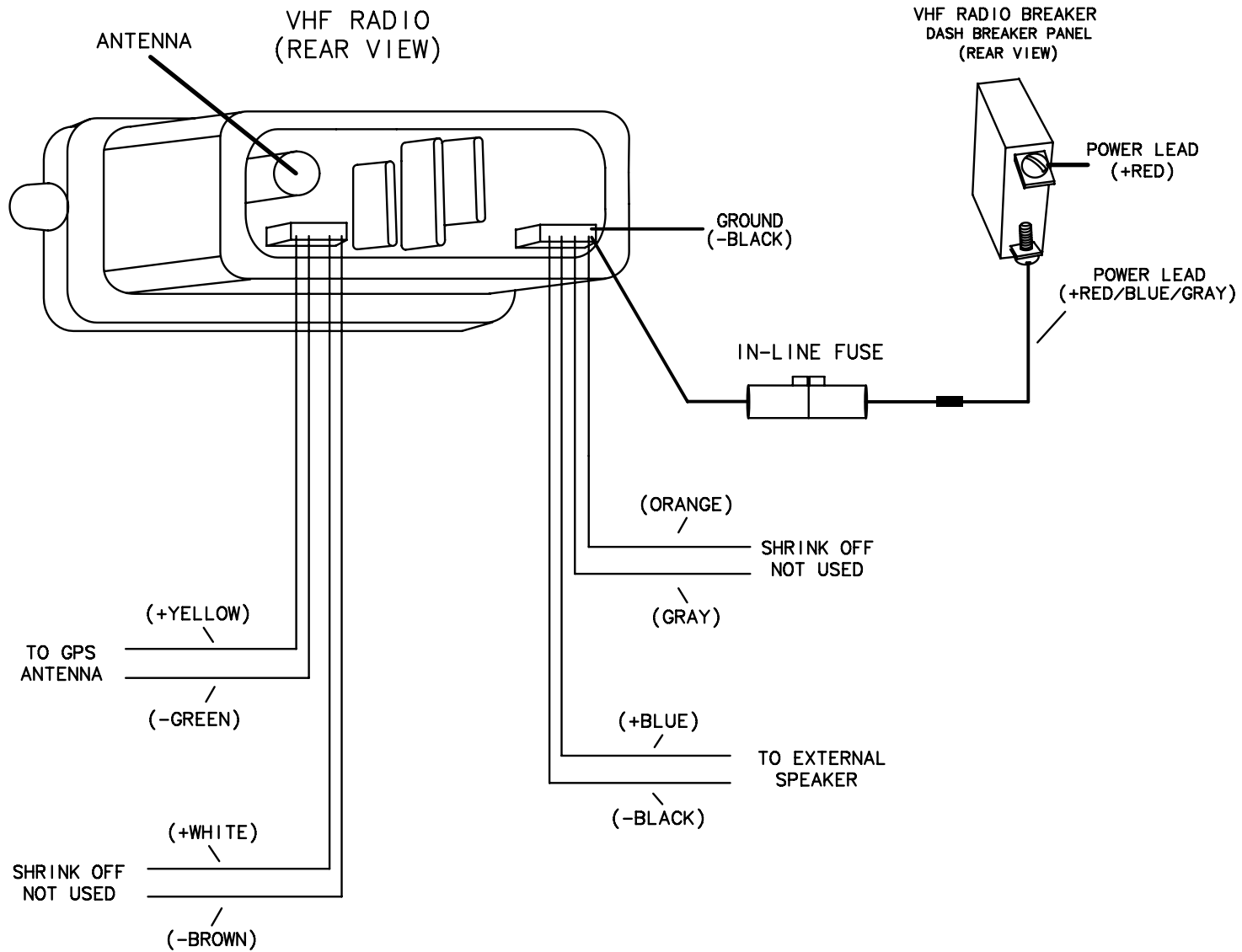

TITLE: VHF RADIO		THUNDERBIRD PRODUCTS
		P.O. BOX 1003
MOD.: 400 SSC	DR BY: KPP	DECATUR IN., 46733
NO.: 62	DATE: 10-5-18	(260) 724-9111

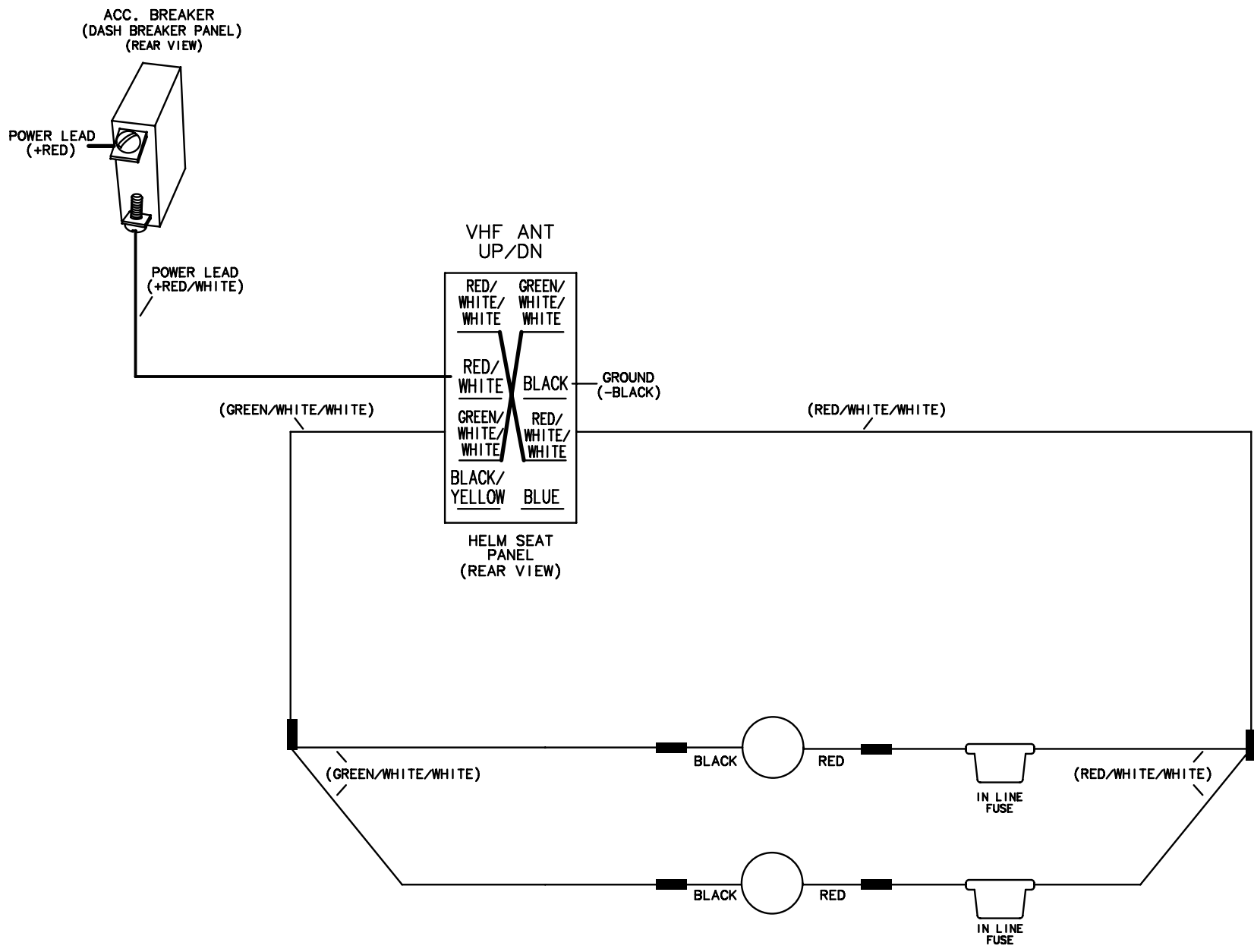

TITLE: VHF ANTENNA, AUTO		THUNDERBIRD PRODUCTS
		P.O. BOX 1003
MOD.: 400 SSC	DR BY: KPP	DECATUR IN., 46733
NO.: 63	DATE:10-5-18	(260) 724-9111

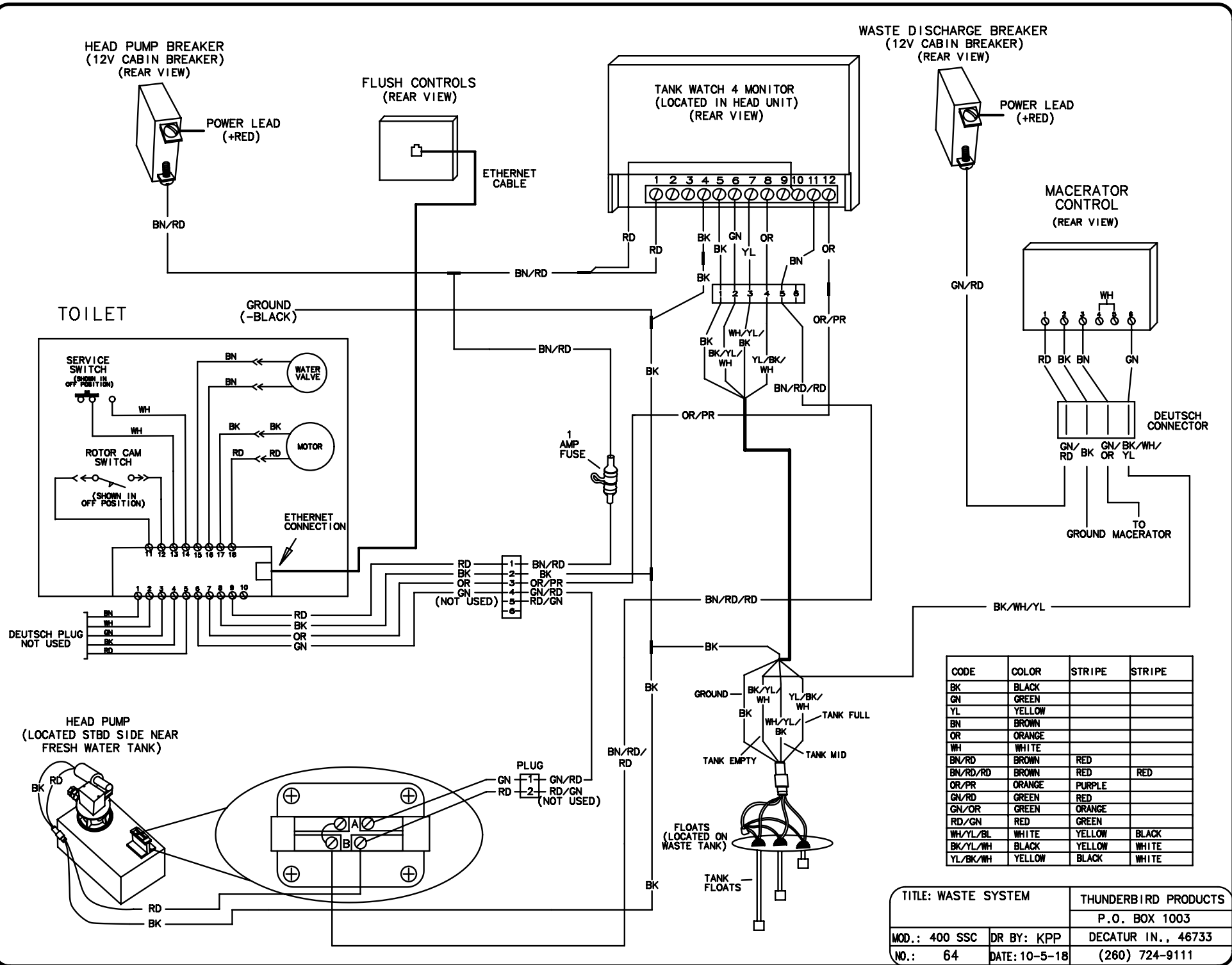

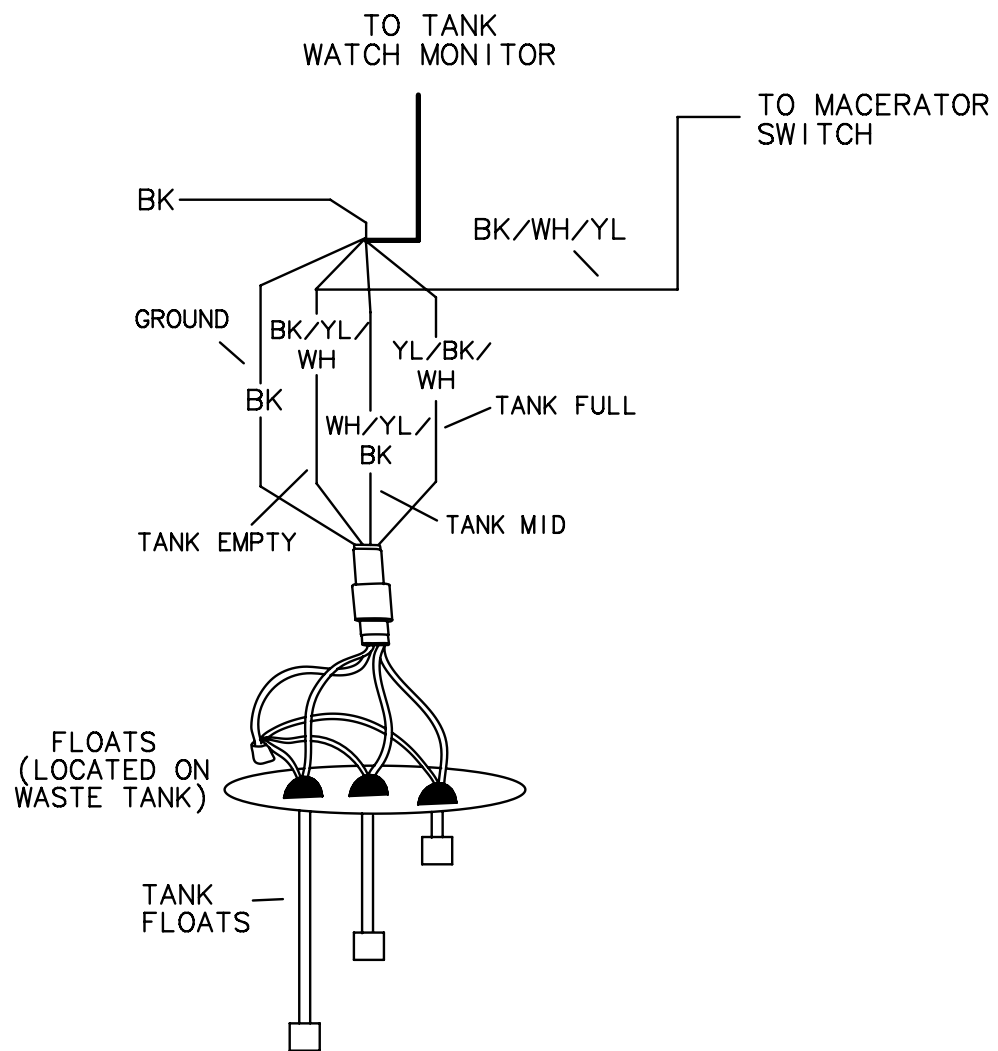

TITLE: WASTE SYSTEMS (FLOAT)		THUNDERBIRD PRODUCTS
		P.O. BOX 1003
MOD.: 400 SSC	DR BY: KPP	DECATUR IN., 46733
NO.: 65	DATE: 10-5-18	(260) 724-9111

WASTE SYSTEM BREAKER
(DC BREAKER PANEL)
(REAR VIEW)

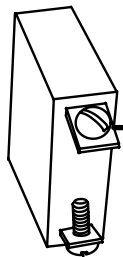

POWER LEAD
(+RED)

BN/RD

TANK WATCH 4 MONITOR
(LOCATED IN HEAD UNIT)
(REAR VIEW)

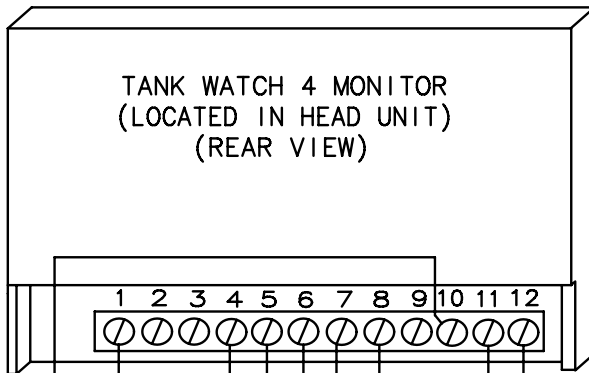

1 2 3 4 5 6 7 8 9 10 11 12

RD

RD

BK

BK

GN

YL

OR

BN

OR

GROUND
(-BLACK)

BK

WH/YL/
BK

BK/YL/
WH

YL/BK/
WH

OR/PR

BN/RD/RD

FLUSH
TOILET

POWER TO
VACUUM PUMP

TO FLOAT
ON WASTE TANK

TITLE: WASTE SYSTEM (TANK WATCH)		THUNDERBIRD PRODUCTS
		P.O. BOX 1003
MOD.: 400 SSC	DR BY: KPP	DECATUR IN., 46733
NO.: 66	DATE:10-5-18	(260) 724-9111

TOILET

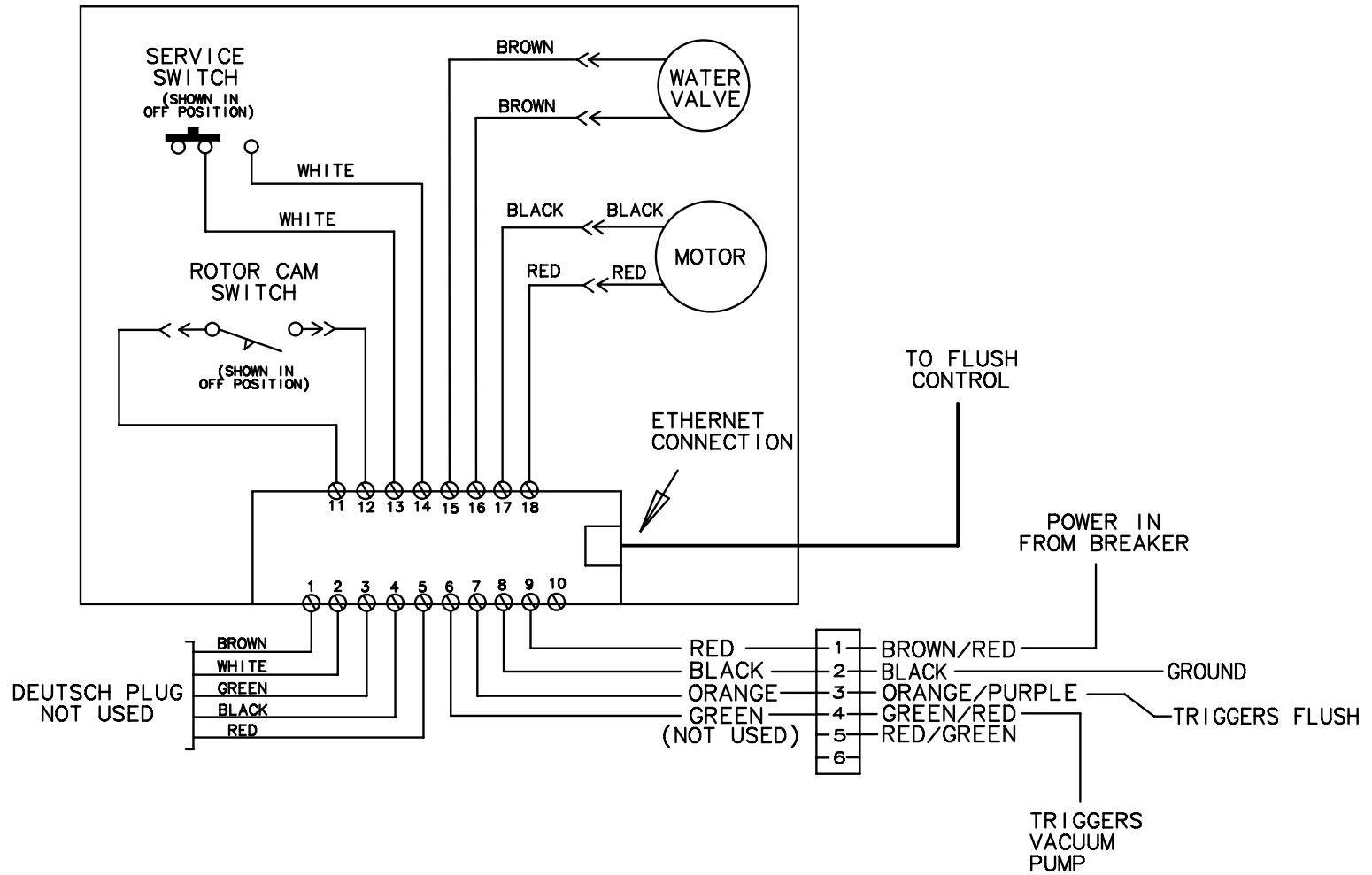

TITLE: WASTE SYSTEM (TOILET)		THUNDERBIRD PRODUCTS
		P.O. BOX 1003
MOD.: 400 SSC	DR BY: KPP	DECATUR IN., 46733
NO.: 67	DATE: 10-5-18	(260) 724-9111

LEGEND

MOTOR



PLUG
INTERCONNECT



FRESH WATER PUMP BREAKER
(CABIN DC PANEL)
(REAR VIEW)

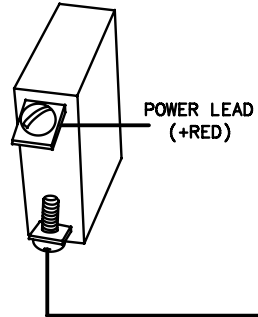

POWER LEAD
(+RED)

GROUND
(-BLACK)

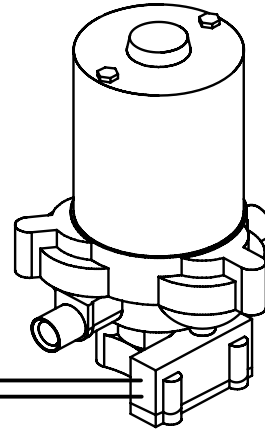

WATER PUMP
(ENGINE AREA)

POWER LEAD
(+BROWN/BLACK)

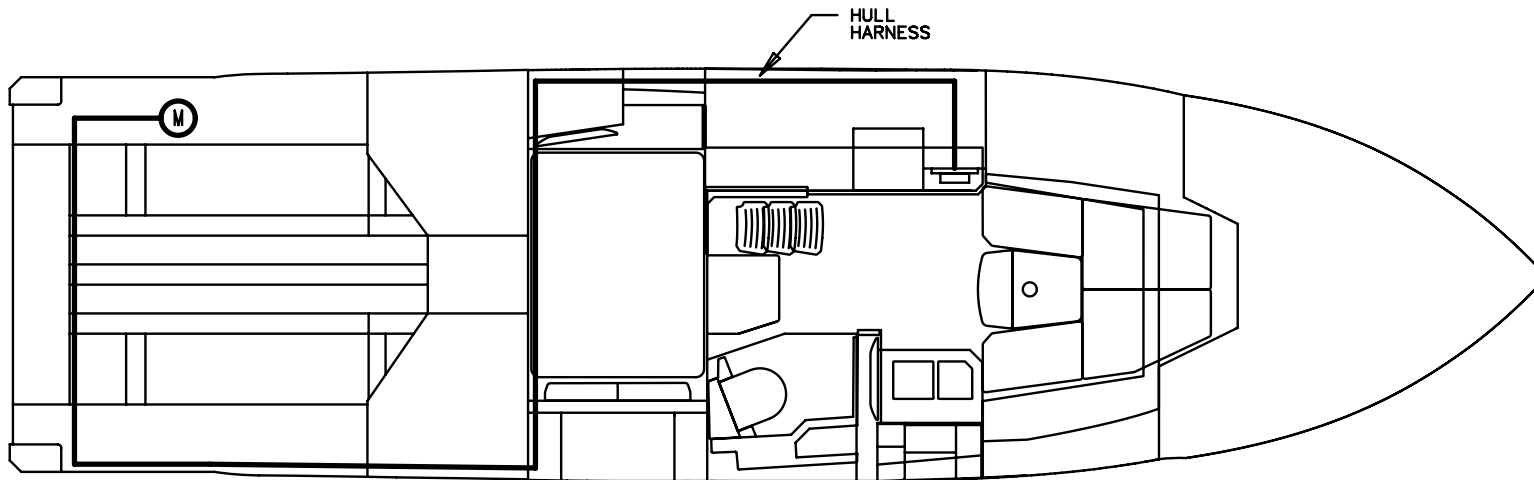

TITLE: WATER PUMP (ELECTRICAL)		THUNDERBIRD PRODUCTS
		P.O. BOX 1003
MOD.: 400 SSC	DR BY: KPP	DECATUR IN., 46733
NO.: 68	DATE: 10-5-18	(260) 724-9111

**BOW WINDLASS
BUTTONS**

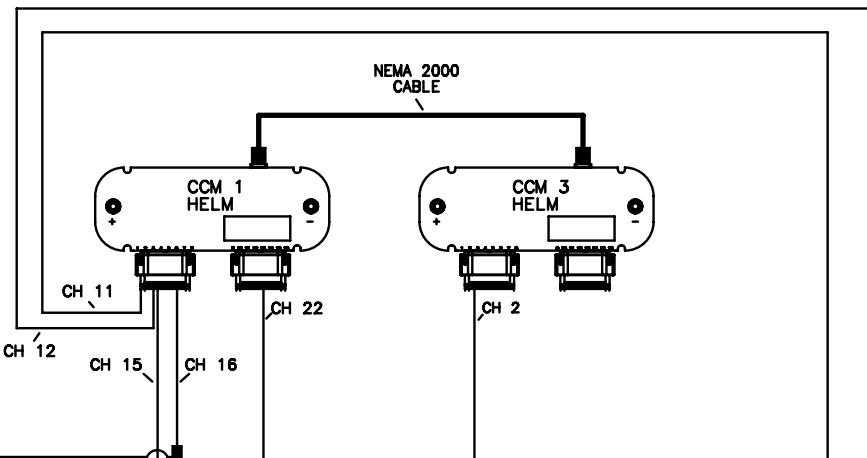
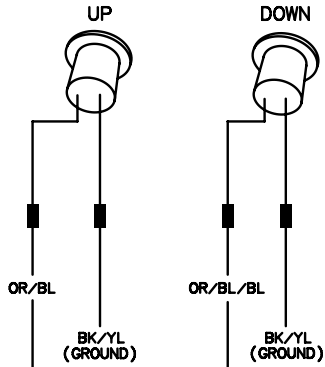

CODE	COLOR	STRIPE	STRIPE
BK	BLACK		
BL	BLUE		
RD	RED		
BN	BROWN		
GY	GRAY		
YL	YELLOW		
WH	WHITE		
TN/GY	TAN	GRAY	
OR/BL	ORANGE	BLUE	
OR/BL/BL	ORANGE	BLUE	BLUE
OR/YL/BL	ORANGE	YELLOW	BLUE
OR/YL/RD	ORANGE	YELLOW	RED

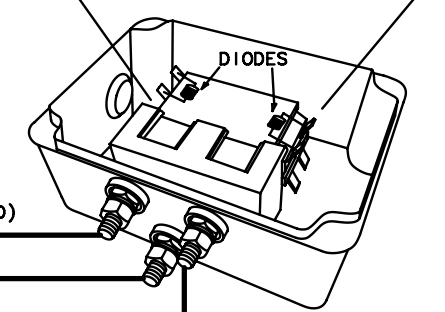
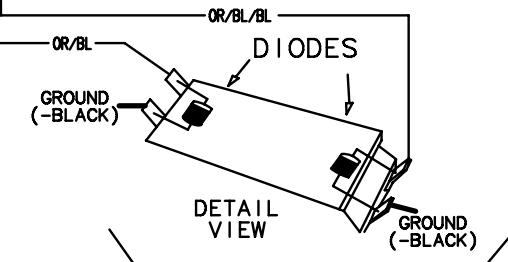
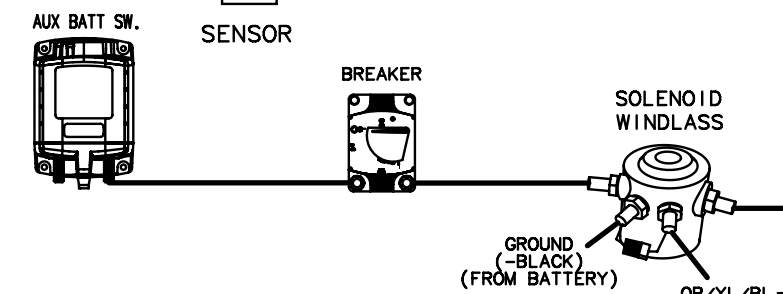
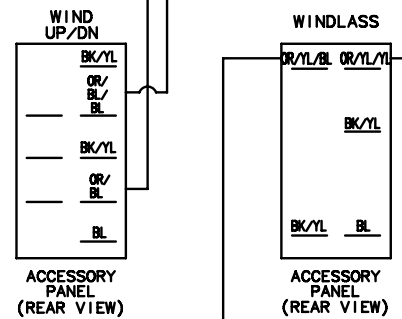
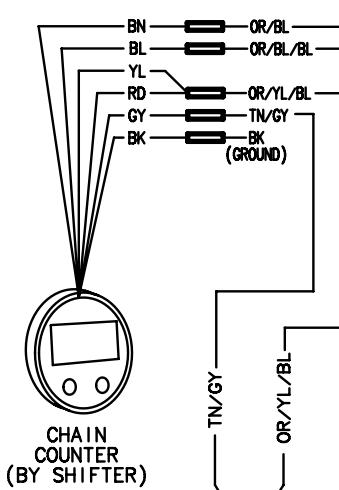

TITLE: WINDLASS		THUNDERBIRD PRODUCTS	
		P.O. BOX 1003	
MOD.: 400 SSC	DR BY: KPP	DECATUR IN., 46733	
NO.: 69	DATE: 10-5-18	(260) 724-9111	

LEGEND

CONNECTOR 

DIODE 

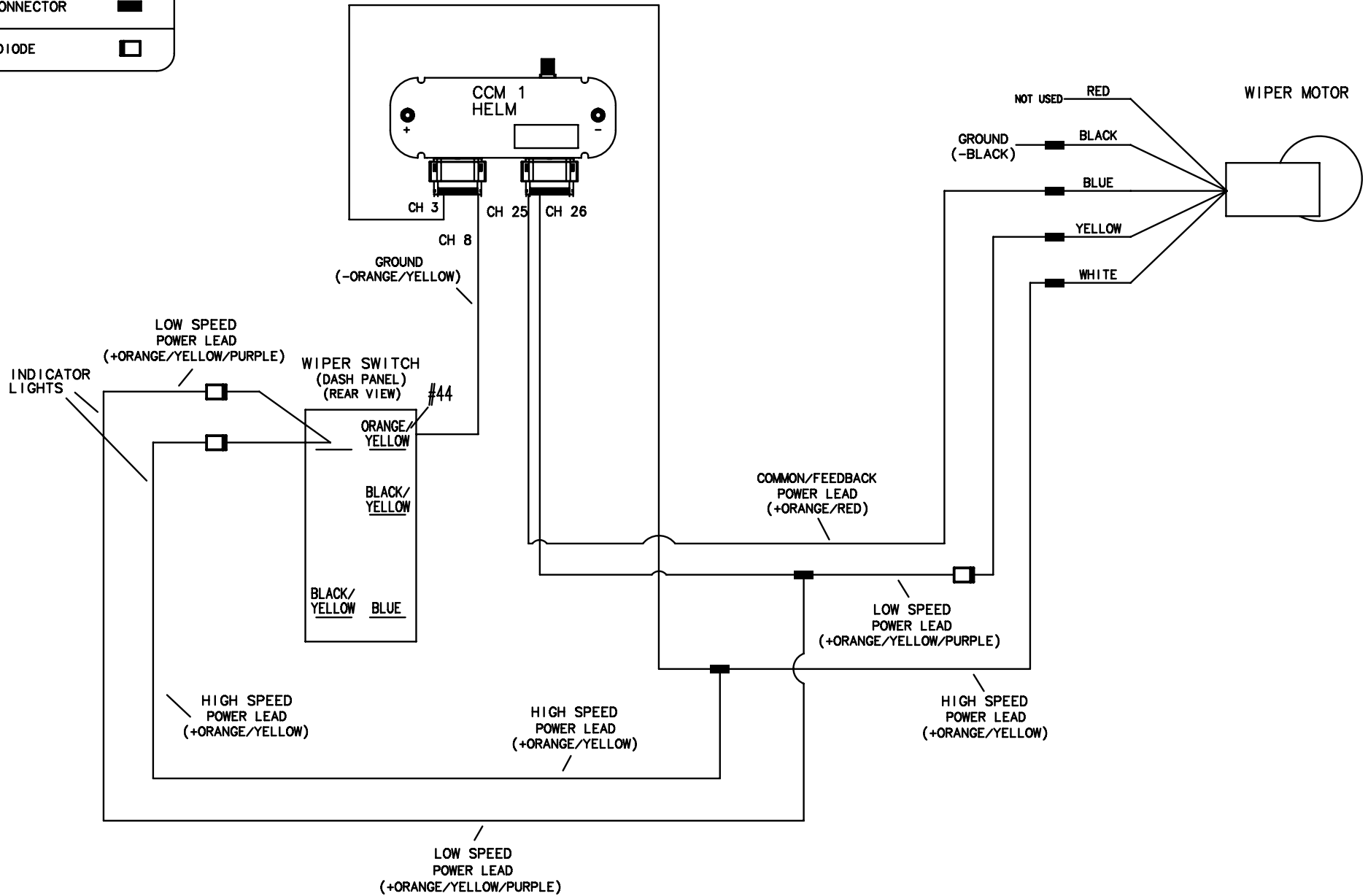

TITLE: WIPER		THUNDERBIRD PRODUCTS
		P.O. BOX 1003
MOD.: 400 SSC	DR BY: KPP	DECATUR IN., 46733
NO.: 70	DATE: 10-5-18	(260) 724-9111

OPTION FROM SIDE HELM PANEL
USED TO FILL THIS SPOT.

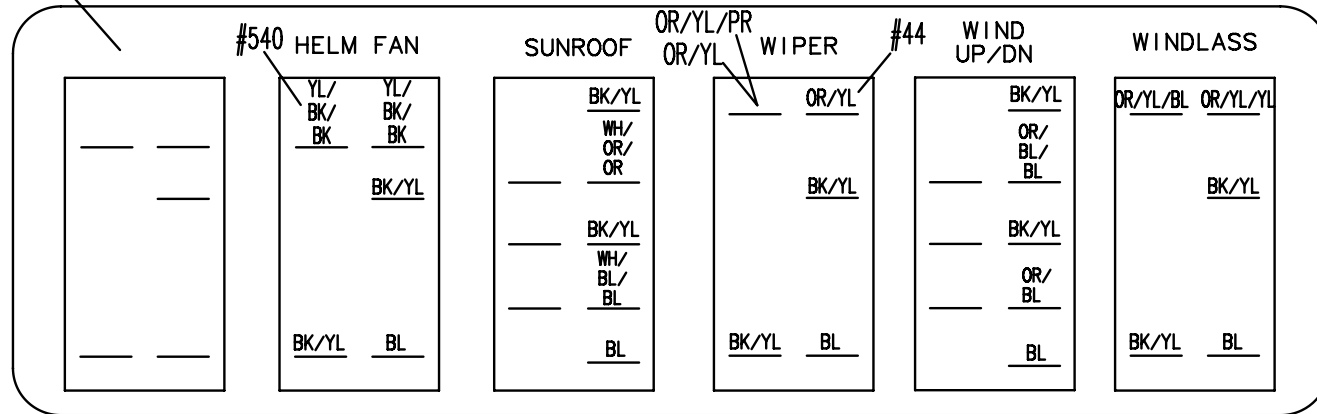

STBD

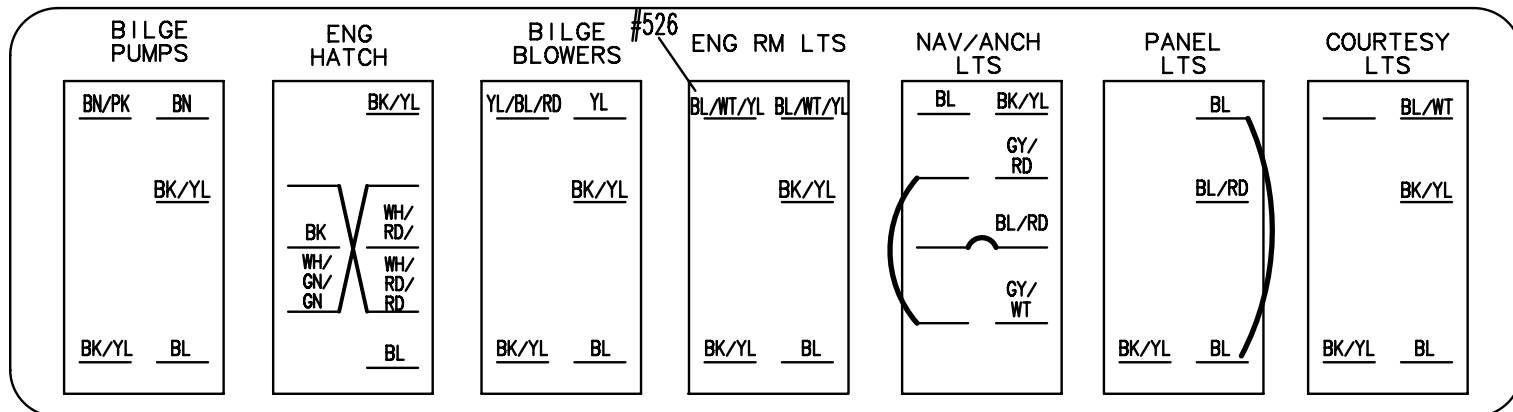

PORT

(REAR VIEW)

TITLE: ACCESSORY PANEL		THUNDERBIRD PRODUCTS
		P.O. BOX 1003
MOD.: 400 SSC	DR BY: KPP	DECATUR IN., 46733
NO.: 71	DATE: 10-5-18	(260) 724-9111

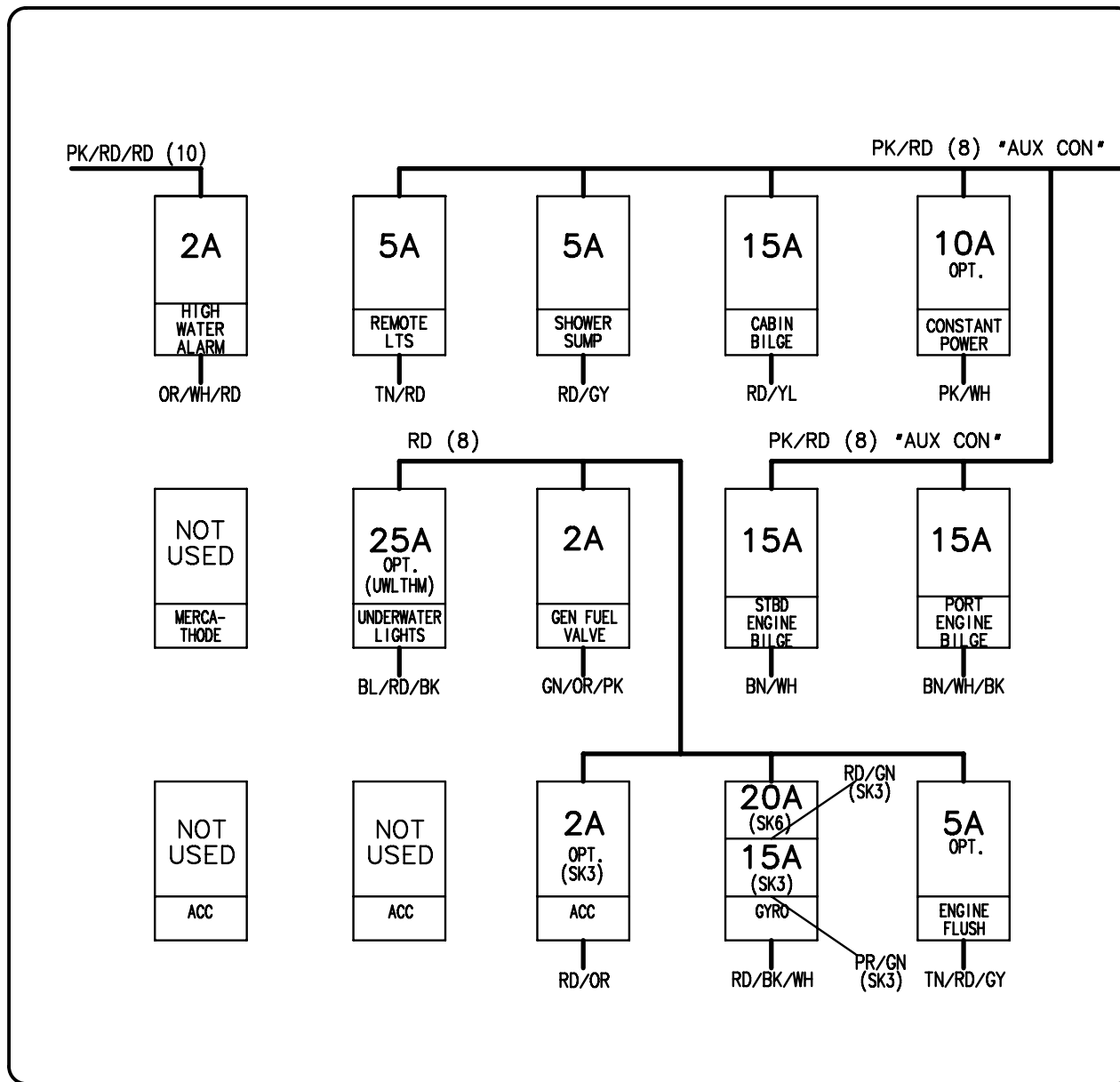

(REAR VIEW)

(LOCATED PORT SIDE
OF ENGINE AREA)

NOTE: BREAKER SIZES SUBJECT TO
CHANGE WITHOUT NOTICE.

TITLE: AFT BREAKER PANEL		THUNDERBIRD PRODUCTS
		P.O. BOX 1003
MOD.: 400 SSC	DR BY: KPP	DECATUR IN., 46733
NO.: 72	DATE: 10-5-18	(260) 724-9111

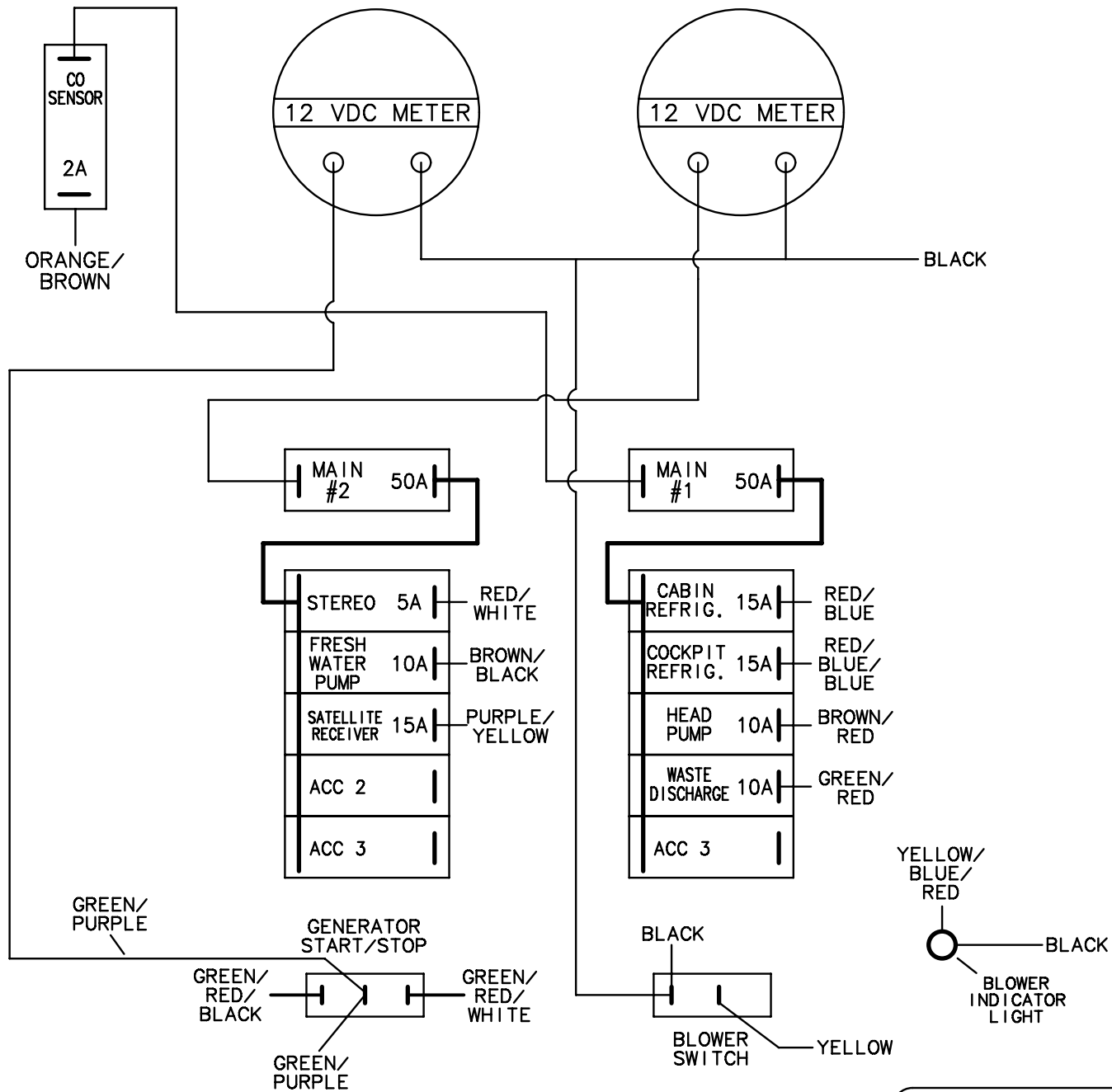

(REAR VIEW)

NOTE: BREAKER SIZES SUBJECT TO CHANGE WITHOUT NOTICE.

TITLE: CABIN DC PANEL		THUNDERBIRD PRODUCTS
		P.O. BOX 1003
MOD.: 400 SSC	DR BY: KPP	DECATUR IN., 46733
NO.: 73	DATE: 10-5-18	(260) 724-9111

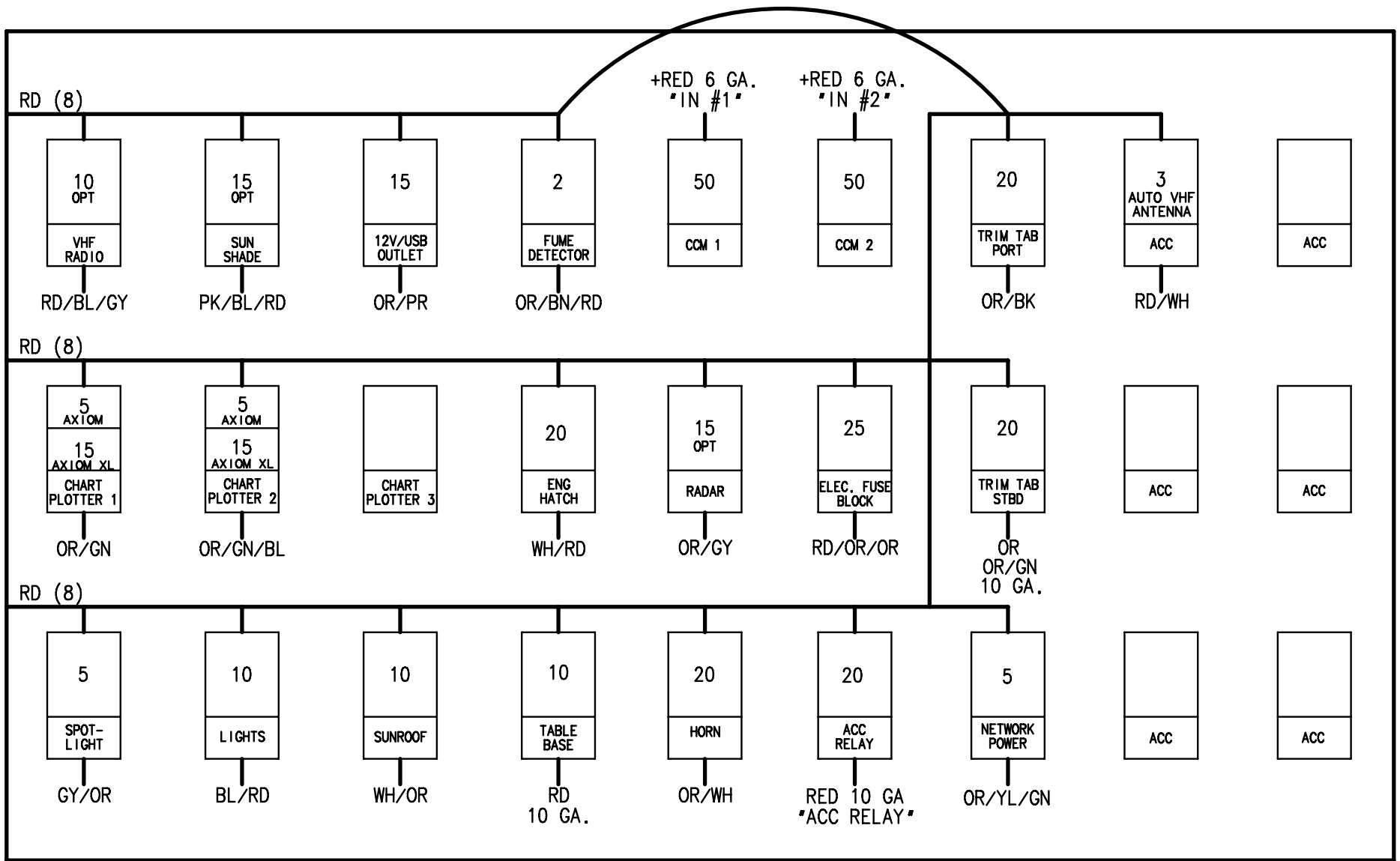

(REAR VIEW)

NOTE: BREAKER SIZES SUBJECT TO CHANGE WITHOUT NOTICE.

TITLE: DASH BREAKER PANEL		THUNDERBIRD PRODUCTS
		P.O. BOX 1003
MOD.: 400 SSC	DR BY: KPP	DECATUR IN., 46733
NO.: 74	DATE: 10-5-18	(260) 724-9111

DOCKING
LTS

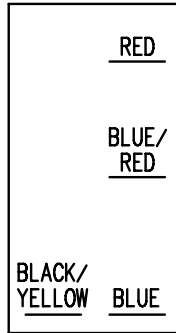

SPREADER
LTS

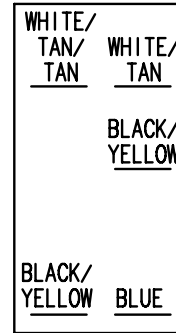

VHF ANT
UP/DN

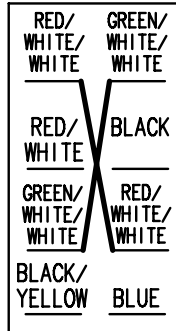

UWL
LTS

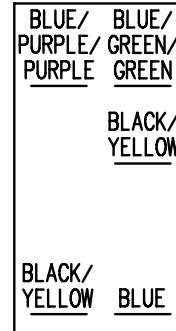

(REAR VIEW)

TITLE: HELM SWITCH PANEL		THUNDERBIRD PRODUCTS
		P.O. BOX 1003
MOD.: 400 SSC	DR BY: KPP	DECATUR IN., 46733
NO.: 75	DATE: 10-5-18	(260) 724-9111

LEGEND

MOTOR/PUMP



BILGE HOSE 1 1/8"



BILGE PUMP
(ENGINE AREA)

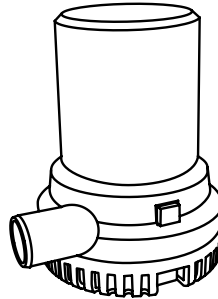

BILGE PUMP
(ENGINE AREA)

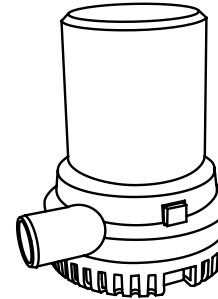

BILGE PUMP
(CABIN)

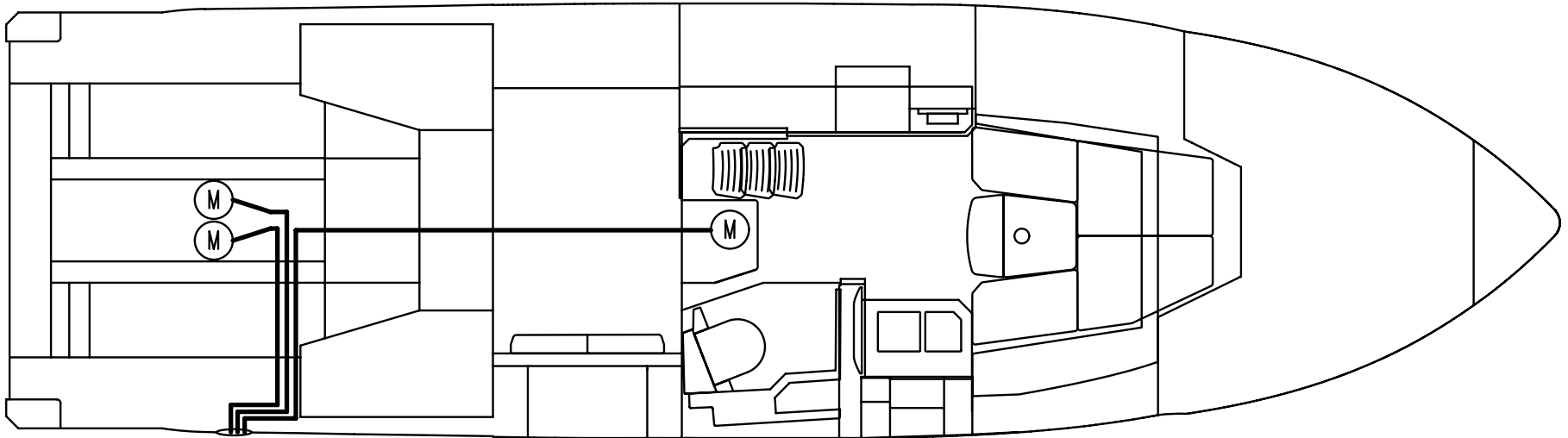
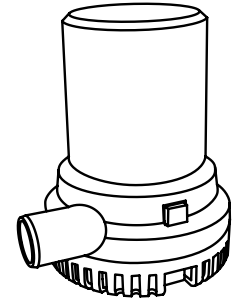

TITLE: BILGE PUMPS PLUMBING		THUNDERBIRD PRODUCTS
		P.O. BOX 1003
MOD.: 400 SSC	DR BY: KPP	DECATUR IN., 46733
NO.: 76	DATE: 10-5-18	(260) 724-9111

LEGEND

DRAIN HOSE ———

PVC HOSE - - - - -

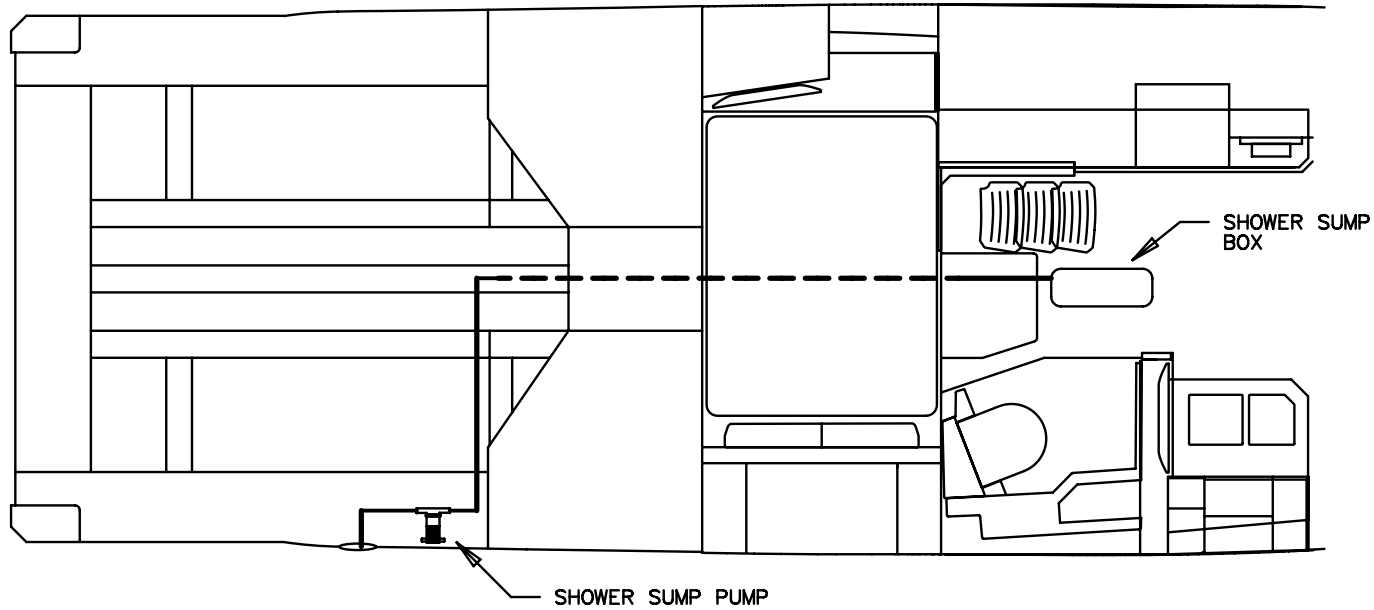

TITLE: SHOWER SUMP (PLUMBING)		THUNDERBIRD PRODUCTS
		P.O. BOX 1003
MOD.: 400 SSC	DR BY: KPP	DECATUR IN., 46733
NO.: 77	DATE: 10-5-18	(260) 724-9111

LEGEND

1 1/4 INCH
SANITATION HOSE

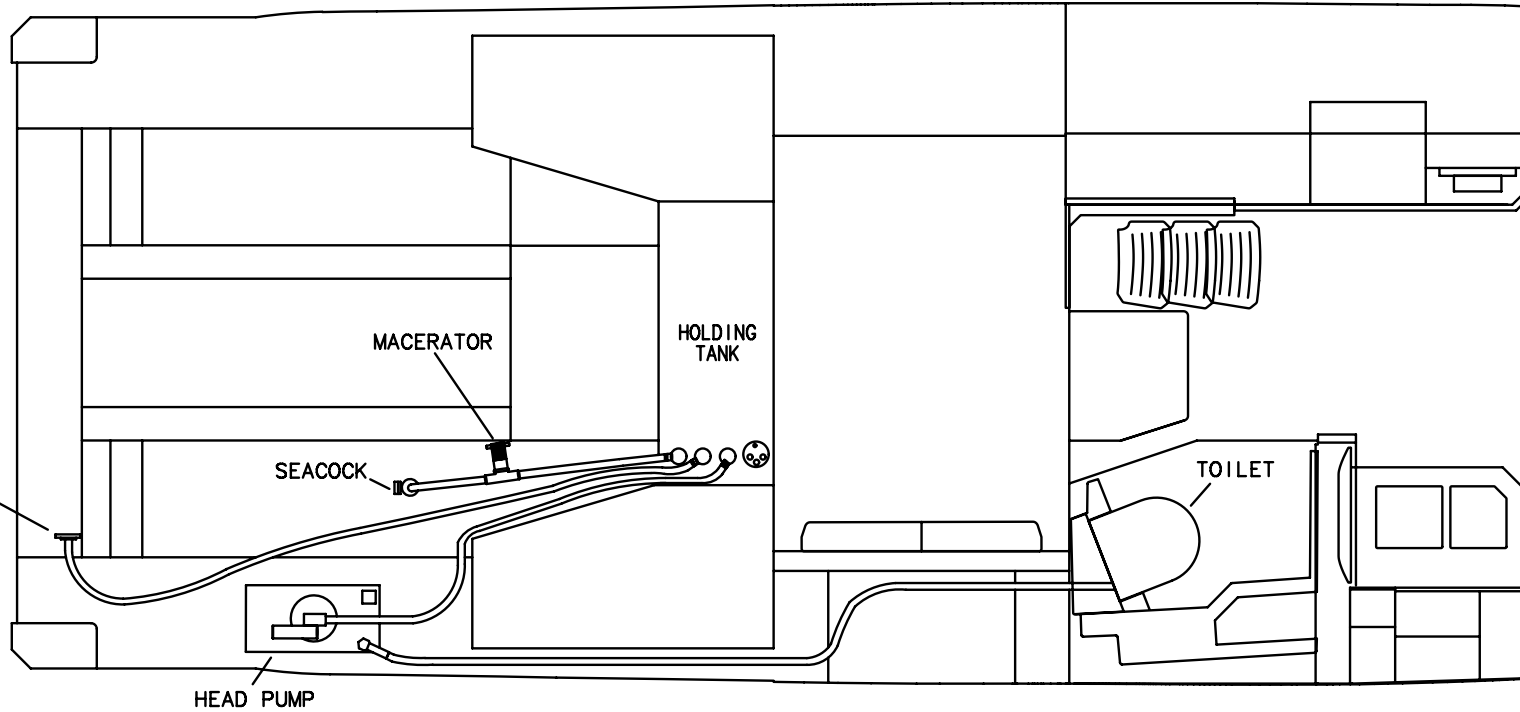

TITLE: WASTE SYSTEM W/ OPT. MAC (PLUMBING)		THUNDERBIRD PRODUCTS
		P.O. BOX 1003
MOD.: 400 SSC	DR BY: KPP	DECATUR IN., 46733
NO.: 78	DATE: 10-6-18	(260) 724-9111

LEGEND

MOTOR (M)

WATER LINE (—)

WATER TANK VENT (- - -)

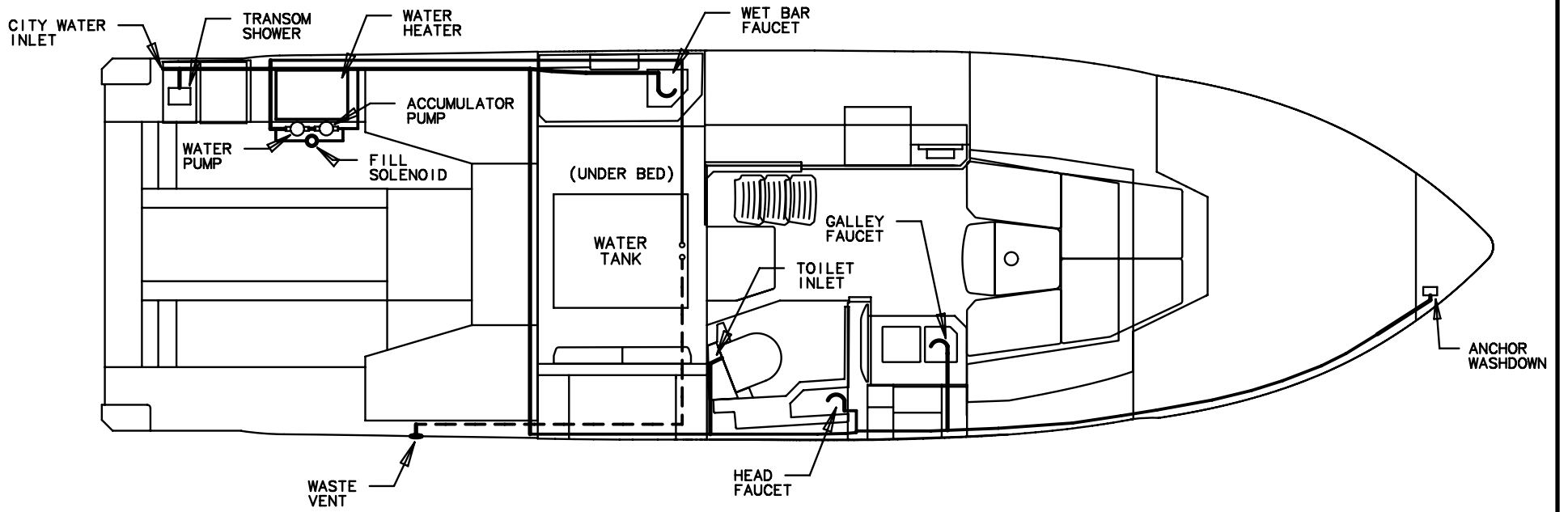

TITLE: WATER SYSTEM (PLUMBING)		THUNDERBIRD PRODUCTS
		P.O. BOX 1003
MOD.: 400 SSC	DR BY: KPP	DECATUR IN., 46733
NO.: 79	DATE: 10-5-18	(260) 724-9111

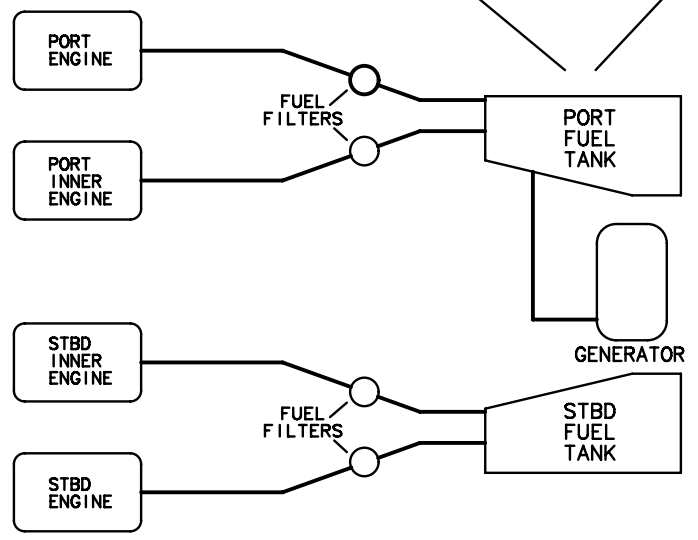
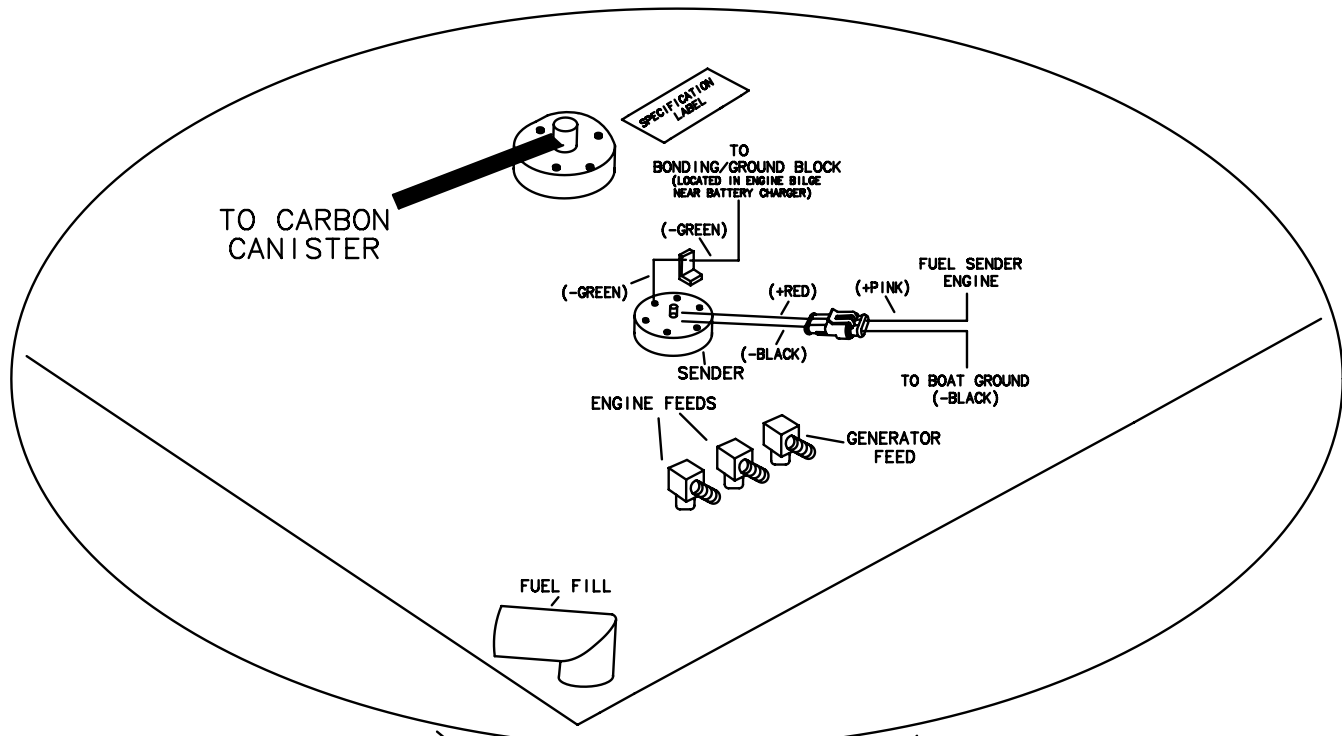

TITLE: FUEL PLUMBING		THUNDERBIRD PRODUCTS
		P.O. BOX 1003
MOD.: 400 SSC	DR BY: KPP	DECATUR IN., 46733
NO.: 80	DATE:10-5-18	(260) 724-9111